

## Year 9 intervention lessons and resources

These lessons are designed to support teachers working with Year 9 pupils who need to consolidate work to secure level 5. They are not appropriate for the majority of pupils in Year 9 who are already at level 5 or above and who are working on the main Year 9 teaching programme for mathematics. When using the lessons, teachers need to take into account pupils' prior knowledge and experience of the topics.

Most of the lessons are drawn from existing Key Stage 3 Strategy materials to support the main Year 8 mathematics teaching programme together with Year 9 booster lessons. The lessons focus on teaching strategies to address the stated learning objectives.

The lessons are linked to units of work corresponding to the sample medium-term plan: Year 9 intervention (see section 2). Maintaining the order of the units will help to ensure progression and continuity, building up pupils' understanding systematically during the year.

Lesson starters provide opportunities to recall previously learned facts and to practise skills. Some of the starters introduce ideas that are then followed up in the main part of the lesson.

You can also base the teaching in a lesson on a single test question. This helps pupils realise the level of difficulty expected of them as well as helping them gain familiarity with the style of test questions.

You could complete the main part of a lesson by:

- extending your questioning of pupils;
- increasing the number of examples that you demonstrate.

It is important that while pupils are working on a task you continue to teach by rectifying any misconceptions and explaining key points.

Use the final plenary to check pupils' learning against the lesson objectives. These define the standard required – what pupils need to know and be able to do in order to reach level 5 in mathematics at the end of Key Stage 3.

When you are preparing to use the lessons, read them through using a highlighter pen to mark key teaching points and questions. You can then refer to these quickly while you are teaching. Annotate the lesson plan to fit the needs of your pupils.

You will need to prepare overhead projector transparencies (OHTs) and occasional handouts. You also will need to select and prepare resources, matched to pupils' needs, to provide practice and consolidation during the lesson and for homework.

## Securing level 5 in mathematics: Year 9 intervention

Lesson	Description	Source
Lesson 9N1.1	Fractions, decimals and percentages 1	Booster kit: lesson 2
Lesson 9N1.2	Fractions, decimals and percentages 2	Booster kit: lesson 3
Lesson 9N1.3	Fractions, decimals and percentages 3	Transition: lesson N2.1
Lesson 9N1.4	Fractions, decimals and percentages 4	Transition: lesson N2.2
Lesson 9S1.1	Lines and angles	Booster kit: lesson 8
Lesson 9A2.1	Solving linear equations using a number line	Constructing and solving linear equations: lesson 8.1
Lesson 9A2.2	Solving linear equations using the matching method	Constructing and solving linear equations: lesson 8.2
Lesson 9D1.1	Handling data	Booster kit: lesson 14
Lesson 9S2.1	Area and perimeter	Booster kit: lesson 9
Lesson 9N3.1	Place value	Booster kit: lesson 1
Lesson 9N3.2	Using a calculator	Booster kit: lesson 4
Lesson 9N4.1	Ratio and proportion 1	Booster kit: lesson 5
Lesson 9N4.2	Ratio and proportion 2	Booster kit: lesson 15
Lesson 9N4.3	Proportion or not?	Proportional reasoning mini-pack: handout PR3 and resource sheets 'Proportion or not?'
Lesson 9D2.1	Probability	Booster kit: lesson 11
Lesson 9A4.1	Sequences	Booster kit: lesson 7
Lesson 9A4.2	Algebraic expressions	Booster kit: lesson 6
Lesson 9A4.3	Algebraic equations	Booster kit: lesson 13
Lesson 9P1.1	Problem solving	Booster kit: lesson 16
Lesson 9P1.2	Thinking proportionally 1	Transition: lesson P1.1
Lesson 9P1.3	Thinking proportionally 2	Transition: lesson P1.2
Lesson 9P1.4	Solving word problems	Booster kit: lesson 12

## OBJECTIVES

- Use the equivalence of fractions, decimals and percentages to compare proportions.
- Calculate percentages.

## STARTER

15 minutes

## Vocabulary

equivalent  
recurring decimal

## Resources

OHTs 9N1.1a and  
9N1.1b

Show **OHT 9N1.1a** and ask pupils to find the other two values – fraction, decimal or percentage – equivalent to the one you point at.

**Q** If you know  $\frac{1}{5}$  as a decimal, how do you find  $\frac{4}{5}$ ?

Pay particular attention to 0.4 and 0.04, 0.3 and 0.03.

Next, show **OHT 9N1.1b** and write '£240' in the centre of the web. Ask pupils to calculate mentally the fractions, decimals or percentages of £240.

**Q** How did you work out ...? Do you find it easier to use fractions, decimals or percentages when calculating in your head?

Change the starting amount (e.g. 40 grams) and repeat the process.

**Q** Which calculations can still be done mentally?

## MAIN ACTIVITY

35 minutes

## Vocabulary

unitary method

## Resources

OHP calculator  
Calculators for pupils  
OHT 9N1.1c  
Framework examples,  
pages 73–75

Ask pupils to calculate 13% of 48 and then discuss in pairs how they did the calculation. Invite one or two pairs to explain their methods. Discuss methods used, which might include:

- $10\% + 1\% \times 3$ ;
- find 1%, then 13% (unitary method);
- $0.13 \times 48$ .

Explain the equivalence of 13%,  $\frac{13}{100}$  and 0.13.

Use an OHP calculator to demonstrate the key sequence to calculate 13% of 48 ( $0.13 \times 48$ ). Give pupils a few examples to practise similar calculations on their own calculators. Include examples such as 8% of £26.50,  $12\frac{1}{2}\%$  of £98. Check pupils' understanding of these examples.

Ask pupils where they might see percentages in real life. Introduce **OHT 9N1.1c**, which includes some applications of percentages, and ask pupils to solve the problems. For level 6 use questions from the Framework Year 9 supplement of examples, page 75.

## PLENARY

10 minutes

## Resources

OHT 9N1.1c

Pick two questions on **OHT 9N1.1c** and ask pupils to share methods and solutions.

**Q** What is the equivalent decimal?

**Q** How did you find 3.5%? Show the key sequence on the OHP calculator.

You could extend calculations to include a percentage increase.

## KEY IDEAS FOR PUPILS

- Calculate equivalent fractions, decimals and percentages.
- Use a calculator, where necessary, to calculate percentages of quantities.

# Matching fractions, decimals and percentages

20%	$\frac{2}{5}$	$\frac{1}{10}$	$\frac{1}{3}$	0.125	$\frac{2}{3}$
$\frac{3}{10}$	$\frac{3}{4}$	12.5%	$\frac{1}{50}$	$\frac{1}{4}$	30%
25%	0.02	$\frac{1}{5}$	0.6	75%	2%
0.1	66. $\dot{6}$ %	0.25	$\frac{1}{8}$	0. $\dot{6}$	60%
0.4	0.2	$\frac{1}{25}$	0. $\dot{3}$	40%	0.04
4%	$\frac{3}{5}$	33. $\dot{3}$ %	10%	0.3	0.75

## 9N1.1b Spider diagram

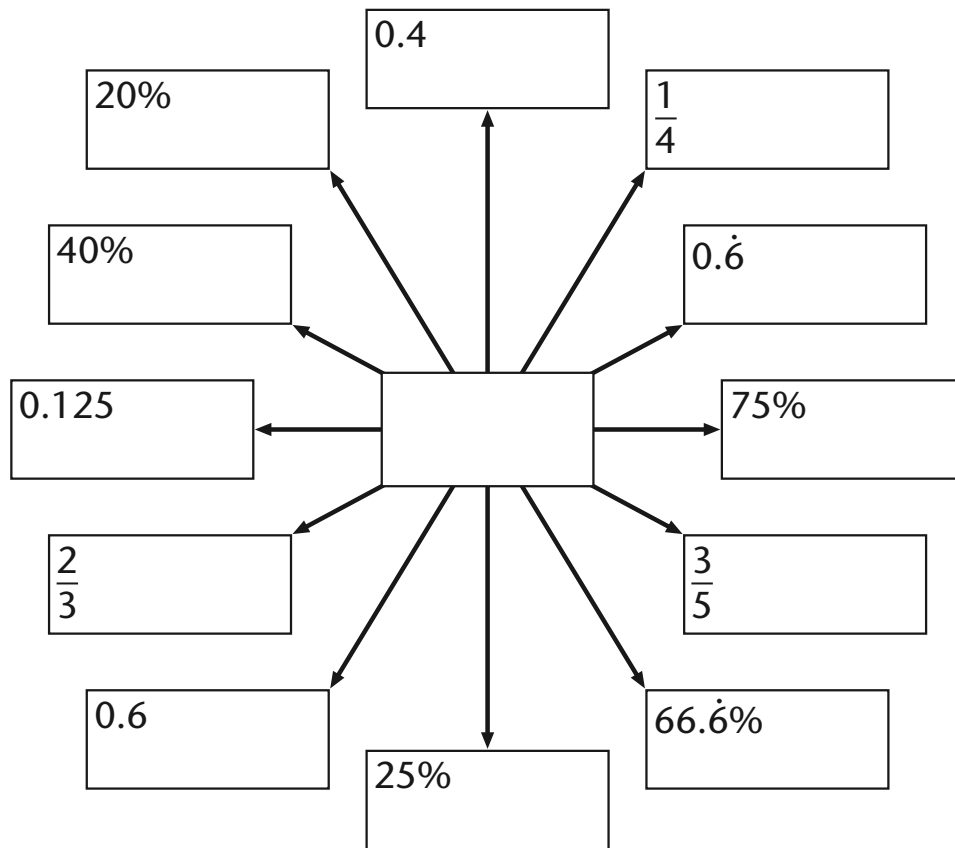

## Percentage problems

---

- 1 An alloy is made from 95% copper, 3.5% tin and 1.5% zinc.

How much tin is there in 1 kg of the alloy?
- 2 The population of Greece is 10 million. 37% of the population is aged 15 to 39.

How many people is this?
- 3 An ice-cream label lists the contents as 17.5% fat.

How much fat is there in 750 g of ice-cream?
- 4 A fabric is made from 83% viscose, 10% cotton and 7% nylon.

How much viscose is needed to make 1.5 tonnes of the fabric?

## OBJECTIVES

- Calculate percentages and find the outcome of a given percentage increase or decrease.

## STARTER

15 minutes

## Vocabulary

partition  
percentage decrease  
percentage increase

## Resources

OHT 9N1.2a  
Mini-whiteboards  
(optional)

Using the target number board on OHT 9N1.2a, ask pupils to calculate a percentage increase/decrease of one of the amounts. Invite them to explain how they arrived at their answers. Discuss their methods.

Encourage pupils to use jottings, when appropriate, to record steps in their working.

**Q How did you work that out?**

**Q How did you partition 35%?**

As preparation for the main teaching, ask:

**Q If you increase an amount by 15%, what percentage of the original will you then have?**

## MAIN ACTIVITY

30 minutes

## Vocabulary

percentage decrease  
percentage increase

## Resources

Objects (e.g. pencils)  
Mini-whiteboards  
OHP calculator  
Calculators for pupils  
OHT 9N1.2b  
Framework examples,  
page 77

Discuss examples involving whole numbers of objects, using statements such as:

**Q If something increases by 100%, it doubles. What percentage do you then have?**

**Q How can you describe an increase by 500%?**

Demonstrate this pictorially or with real objects. You need to explain that you have the original 100% *plus* the increase of 500%.

Model an increase of 10%. Demonstrate that this results in a total of 110%: 100% can be represented by 10 pencils, so 1 pencil represents 10% and the new amount, 11 pencils, is 110%.

**Q How do you write 110% as a decimal?**

Model a decrease of 10%. Demonstrate that this leads to 90%: 10 pencils represent 100%, so 1 pencil represents 10%; the new amount of 9 pencils represents 90%.

**Q How do you write 90% as a decimal?**

Repeat this with another example, such as a 20% increase/decrease.

Use a set of short questions to assess whether pupils can generalise these results.

**Q If something increases by 15%, what percentage of the original amount do you then have? (Check that pupils have written 115% on their whiteboards.)  
How do you write that as a decimal?**

Repeat this with a decrease of 35%. Pupils write 65% to represent the final amount.

**Q How do you write this as a decimal?**

Extend to decreasing £450 by 17%. Recap how to calculate 83% of £450, using the OHP calculator (see lesson 9N1.1).

**Q How would you increase £450 by 17%?**

Pupils then need to practise similar calculations. Use the target number board on OHT 9N1.2b. These examples require the use of calculators.

For level 6 use questions from the Year 9 supplement of examples, page 77.

**PLENARY**

15 minutes

Discuss these problems:

- Q** I start with £250 on January 1st. This increases by 10% on February 1st.  
How much do I then have?  
This further increases by 10% on March 1st. How much have I now?
- Q** I start with £250 on January 1st. This increases by 20% on March 1st.  
Is this the same result as before?

Discuss how a 10% increase followed by another 10% increase is not the same as a 20% increase. Go on to illustrate how a 20% increase + 20% increase is not the same as a 40% increase.

**KEY IDEAS FOR PUPILS**

- Calculate percentages of quantities using a calculator.
- Calculate percentage increases and decreases.



Increase	Decrease
----------	----------

£40	70 cm
300 g	1 kg
£12	650 m

by

10%	15%	100%	35%	12.5%
-----	-----	------	-----	-------

Increase	Decrease
----------	----------

£70	83 cm
350 g	1 kg
£12.50	650 m

by

11%	17%	120%	38%	16.5%
-----	-----	------	-----	-------

## OBJECTIVES

- Begin to use the equivalence of fractions, decimals and percentages to compare proportions.
- Recall known facts, including fraction to decimal conversions; use known facts to derive unknown facts, including products such as 0.7 and 6, and 0.03 and 8.
- Consolidate and extend mental methods of calculation, working with decimals, fractions and percentages; solve word problems mentally.

## STARTER

10 minutes

## Vocabulary

convert  
equivalent  
improper  
mixed number

## Resources

Operation cards  
(optional)

Draw a line on the board. Say that this line will be used to record equivalent operations. Label the ends with  $\times 0$  and  $\times 3$ . Invite pupils to choose fraction, decimal or percentage operators to write on the line (or show where fraction, decimal and percentage operation cards should be placed on the line). Encourage pupils to use mixed number, proper and improper fraction, decimal and percentage operation equivalences.

- Q Where should you place  $\times 0.8$ ,  $\times 1\frac{1}{3}$ ,  $\times 1\%$ ,  $\times 2.125$ , ...?
- Q How do you decide where the number should go?
- Q Which operators does  $\times 1.37$  come between?
- Q How can you write this as a fraction operator? As a decimal operator? As a percentage operator?

## MAIN ACTIVITY

40 minutes

## Vocabulary

convert  
denominator  
equivalent  
numerator

## Resources

Resource 9N1.3a,  
cut into cards for  
sorting; one set per  
three or four pupils  
1–100 cards  
Calculators (as  
support)  
Framework examples,  
pages 73–75

Write  $0.8 \times 35$  on the board. Referring to the operation line used in the starter, explain that you can ask the same question in different ways, such as 80% of 35 or  $\frac{4}{5} \times 35$ .

Ask pupils to answer the question and to explain their methods, encouraging mental strategies.

Repeat with different questions. Include questions that may lead to misconceptions, such as  $\times 30\%$  being seen as the equivalent of  $\times \frac{1}{3}$ .

- Q How else could you write 225% of 52?  $1\frac{1}{3}$  of 210?

Give out the sets of cards from **resource 9N1.3a**. Ask pupils to work in pairs to find which calculations are equivalent and to group the cards into sets. Ask pupils to answer the questions and to discuss different strategies for calculating proportions of 72.

**Support:** Use fewer cards. Using calculators may help some pupils identify groups of equivalent calculations.

Collect answers and discuss pupils' approaches in a mini-plenary.

- Q Which calculations did you find difficult?
- Q Were you surprised to find that any of the particular calculations were equivalent?

Write this or a similar list on the board:

$\frac{4}{5}$	35
0.8	40
80%	23

Pose questions from the list, for example:

**Q What is  $\frac{4}{5} \times 35$ ,  $\frac{4}{5} \times 40$ ,  $\frac{4}{5} \times 23$ ?**

Ask two or three pupils to explain how they tackled the questions.

Repeat for 0.8 and for 80%.

**Q Are some questions easier to answer than others?**

Ask pupils, working in pairs, to use sets of 1–100 cards to practise making decisions. First ask them to write each of the three operations ( $\times \frac{4}{5}$ ,  $\times 0.8$ ,  $\times 80\%$ ) on a blank piece of paper. Now they should choose a card in turn from the 1–100 number cards and decide which of the calculations,  $\times \frac{4}{5}$ ,  $\times 0.8$  or  $\times 80\%$ , they would use to tackle the question. They place the card in the appropriate pile.

In a mini-plenary, ask pupils to consider the connections between the numbers they have placed and the decisions they have made.

**Q What made you decide between using  $\times \frac{4}{5}$ ,  $\times 0.8$  and  $\times 80\%$ ?**

**Q Would a different fraction change your decision?**

*Differentiate the activity by changing the range of 1–100 cards that pupils work with.*

## PLENARY

10 minutes

Ask pupils if they can explain the connection between fractions, decimals and percentages.

**Q Can you explain why 20% of 35,  $\frac{1}{5} \times 35$  and  $0.2 \times 35$  give the same answer?**

**Q Can you think of a new set of equivalent fraction, decimal and percentage operators which you did not know at the start of this lesson?**

### KEY IDEAS FOR PUPILS

- It is useful to remember some key equivalences. For example:

$$\frac{1}{10} = 0.1 = 10\% \quad \frac{1}{100} = 0.01 = 1\%$$

$$\frac{1}{5} = 0.2 = 20\%$$

- When you calculate with fractions, decimals or percentages, choose the operator that makes the calculation easy.

$0.03 \times 72$	30% of 72	1.25 of 72	$72 \times 100$
$\frac{1}{10}$ of 72	3% of 72	$\frac{3}{10}$ of 72	$\frac{5}{4}$ of 72
$72 \div \frac{1}{100}$	$0.01 \times 72$	$\frac{1}{100}$ of 72	$33\frac{1}{3}\%$ of 72
125% of 72	$72 \div 10$	1% of 72	$0.3 \times 72$
$\frac{1}{3}$ of 72	$72 \div 0.01$	0.1 of 72	$72 \div 100$

## OBJECTIVES

- Begin to use the equivalence of fractions, decimals and percentages to compare proportions.
- Recall known facts, including fraction to decimal conversions; use known facts to derive unknown facts, including products such as 0.7 and 6, and 0.03 and 8.
- Consolidate and extend mental methods of calculation, working with decimals, fractions and percentages; solve word problems mentally.

## STARTER

20 minutes

Vocabulary  
equivalentResources  
Resource 9N1.4a

Write in the middle of the board:

$$0.7 \times 6 = 4.2$$

Invite pupils to give connected calculations, for example:

$$0.07 \times 6 = 0.42$$

$$0.7 \times 3 = 2.1$$

$$42 \div 0.6 = 70$$

Remind pupils that this is an example of using known facts to work out related facts.

Use the questions on **resource 9N1.4a** to revise mental calculation methods. Discuss alternative methods with pupils.

## MAIN ACTIVITY

30 minutes

Vocabulary  
per  
proportionResources  
Resource 9N1.4b,  
cut into cards for  
sorting; one set per  
three or four pupils

Explain that in this lesson pupils are going to use their mental calculation strategies for decimals, fractions and percentages to solve some problems. As in most thinking skills activities, pupils will work collaboratively in groups.

Ask pupils to work in groups of four. Ask each group to nominate a recorder and a chair.

Share out a set of cards from **resource 9N1.4b** among the members of each group. Ask pupils to look together at the information on the cards and work out how much of each ingredient is used for a batch of ten cakes.

Circulate to observe the calculation strategies and to support the groups' working. Probe pupils' understanding and help them extend and refine their strategies.

## PLENARY

10 minutes

Use the plenary to discuss pupils' results and the strategies used.

- Q Which ingredients did you work out first?**
- Q Did it matter in which order you worked on the different ingredients?**
- Q Were any calculations difficult to do mentally?**
- Q What information did you use to check that your results were right?**

### KEY IDEAS FOR PUPILS

- Read the question (say it to yourself) and decide what information you need to use.
- Choose a calculation strategy that is easy to use with the numbers in the problem.
- Decide how you will check your work.

## Simple problems

---

- 1 A bag of raisins costs £1.20.  
How much do 60 bags cost?
- 2 Fish costs £16 per kilogram.  
How much does  $3\frac{3}{4}$  kg of fish cost?
- 3 Gold costs £160 per ounce.  
How much does  $\frac{3}{8}$  of an ounce cost?
- 4 66.6% of £90
- 5 125% of £48
- 6 A chocolate bar costs £0.30.  
How much do 200 chocolate bars cost?



## 9N1.4b Ten cakes

In total the cakes weigh 7200 grams.	An egg weighs about 50 grams.	Butter weighs 1.7 times as much as the eggs.
The chocolate weighs $\frac{1}{9}$ of the cake.	Raisins weigh 60% of the chocolate.	The flour weighs 175% of the chocolate.
Sugar weighs 225% of the nuts.	Flour weighs $\frac{7}{36}$ of the total.	The nuts weigh 0.7 of the chocolate.
Eggs weigh 125% of the chocolate.	The recipe contains 20 eggs.	The raisins weigh $\frac{6}{7}$ of the nuts.

**Note:** In science mass is measured in grams. Weight is the force of gravity on an object and is measured in newtons. However, it is common practice to refer to 'weighing' as a process when determining the mass of an object.

## OBJECTIVES

- Use correctly the vocabulary, notation and labelling conventions for lines, angles and shapes.
- Solve geometrical problems using side and angle properties and explaining reasoning with diagrams and text.

## STARTER

10 minutes

## Vocabulary

See list below

## Resources

Mini-whiteboards

Ask pupils to listen to the following instructions, and sketch and label the diagram:

*Draw an isosceles triangle ABC.*

*Mark the equal angles and sides.*

*Mark and shade angle ABC.*

*Extend line AB to point D, and mark the exterior angle of the triangle.*

Discuss different orientations of the triangle.

Now ask pupils to do the same for these instructions:

*Draw a pair of parallel lines with an intersecting transversal.*

*Label the parallel lines.*

*Label a pair of corresponding angles with the letter c.*

*Label a pair of alternate angles with the letter a.*

*Label a pair of vertically opposite angles with the letter v.*

Discuss pupils' answers and the relationships between the angles.

- Q Which angles are equal? Do any add up to  $90^\circ$  (complementary)? Do any add up to  $180^\circ$  (supplementary)?**

## MAIN ACTIVITY

40 minutes

## Vocabulary

alternate

complementary

convention

corresponding

definition

equidistant

exterior

interior

intersecting

parallel

perpendicular

supplementary

transversal

vertically opposite

## Resources

OHT 9S1.1a

Mini-whiteboards

Mixed set of questions

Framework examples, pages 16, 17, 183

Tell pupils that they are going to use their knowledge of lines and angles to solve geometrical problems. Model how to solve the problem on **OHT 9S1.1a**.

*ABCD is an isosceles trapezium with AB parallel to DC.*

*P is the mid-point of AB, and  $AP = CD$ ,  $AD = DP$ .*

*$\angle DAP = 75^\circ$ . Calculate the sizes of the other angles.*

Ask pupils to draw and label the diagram and discuss the question in pairs.

- Q What information can you add to the diagram?**

*Label AB and CD as parallel.*

*Label  $AP = PB = CD$ .*

*Label  $BC = AD$  (isosceles trapezium).*

*Label  $\angle DAP = \angle PBC = 75^\circ$  (isosceles trapezium).*

- Q Which angles can you calculate first? Justify your answers.**

Discuss pupils' solutions and model the use of correct language and geometrical reasoning.

$\angle DAP = \angle APD = 75^\circ$  (triangle APD is isosceles)

$\angle ADC = 180^\circ - 75^\circ$  (interior angles, AB and DC are parallel)

$\angle ADP = 180^\circ - 75^\circ - 75^\circ$  (angle sum of triangle is  $180^\circ$ ) and so on

Ask pupils to solve a selection of mixed problems involving lines and angles. Use the Framework supplement of examples, pages 16, 17 and 183, and examples from previous Key Stage 3 test papers.

Check pupils' knowledge of interior and exterior angle properties of polygons.

### PLENARY

10 minutes

Resources  
OHT 9S1.1b

Show **OHT 9S1.1b**, developed from a 1999 test question. Ask pupils to discuss in pairs how to solve the problem and to explain their reasoning.

$$k = 180 - 70 \quad (\text{interior angles})$$

$$3(m + 70) = 360 \quad (\text{angles at a point total } 360^\circ)$$

Demonstrate how pupils should show their working concisely.

#### KEY IDEAS FOR PUPILS

- Know and use the angle properties of parallel lines, and of triangles and polygons.
- Explain reasoning with diagrams and text.

## Isosceles trapezium

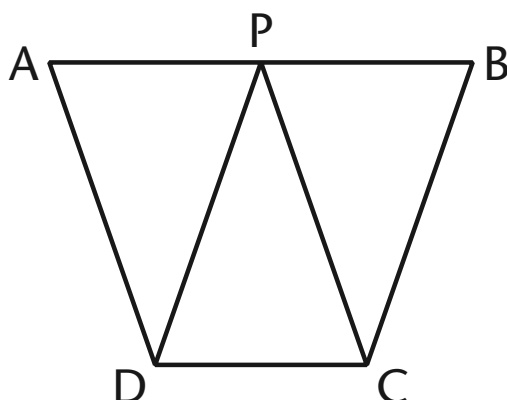

ABCD is an isosceles trapezium with AB parallel to DC.

P is the mid-point of AB, and  $AP = CD$ ,  $AD = DP$ .

$\angle DAP = 75^\circ$ .

Calculate the sizes of the other angles.

The shape below has three identical white tiles and three identical grey tiles.

The sides of each tile are the same length. Opposite sides of each tile are parallel.

One of the angles is  $70^\circ$ .

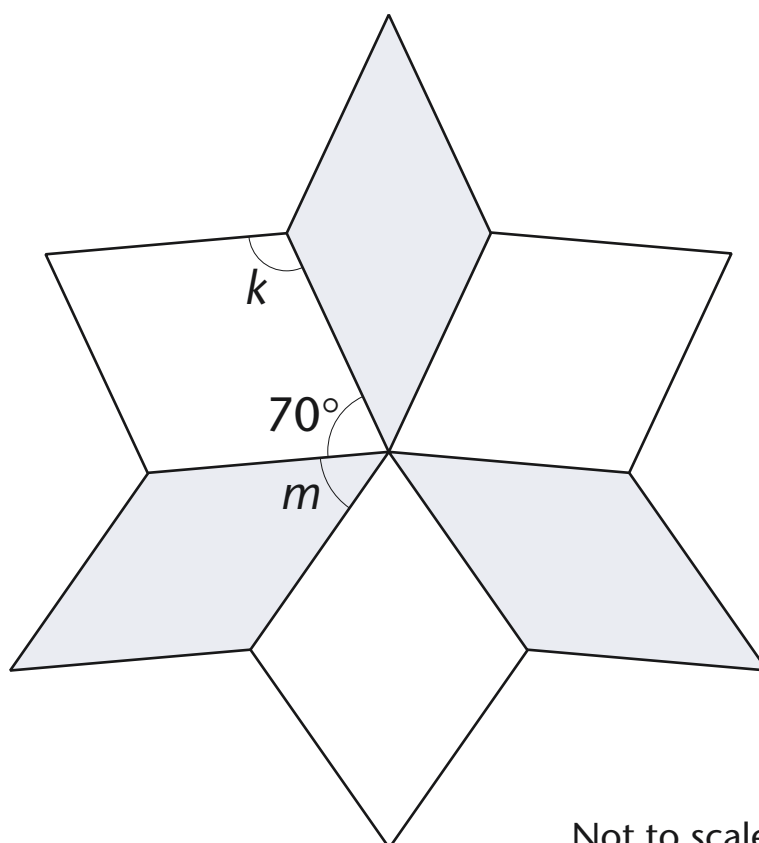

- (a) Calculate the size of angle  $k$ .  
Give a reason for your answer.
- (b) Calculate the size of angle  $m$ .  
Give a reason for your answer.

# Solving linear equations using a number line

## OBJECTIVES

- Construct and solve linear equations with integer coefficients (unknown on either or both sides, without and with brackets) using appropriate methods (e.g. transforming both sides in the same way).
- Represent problems and interpret solutions in algebraic form.
- Suggest extensions to problems and generalise.

## STARTER

10 minutes

## Vocabulary

equation  
unknown  
number line  
interpretation  
representation  
matching

Write on the board the equation  $360 = 72 + 3x$ .

**Q Can anyone describe a situation that could lead to this equation?**

Encourage a variety of explanations including the reference to the angles of a quadrilateral or sectors on a pie chart.

**Q Who can solve this equation?**

Ask for volunteers and encourage a variety of responses. Some pupils will be able to use 'matching' or 'balancing' methods. Others may still need the support of a number line, for example:

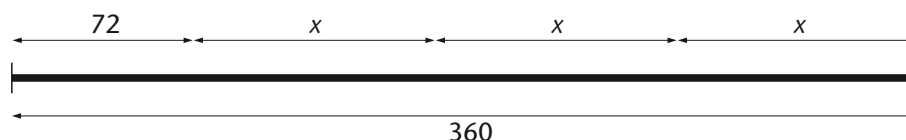

By matching equal lengths show that:

$$360 = 72 + x + x + x$$

**Q So what must  $x + x + x$  be equal to?**

$$288 = x + x + x$$

**Q And how do I now calculate the value of  $x$ ?**

$$96 = x$$

Check that pupils understand what  $x$  represents.

**Q Does the solution make sense in the context of the question?**

**Q How many different solutions are there?**

Establish there is only one solution.

**MAIN ACTIVITY****35 minutes****Vocabulary**

solve  
equation  
unknown  
equivalent equation  
matching  
like terms

**Resources**

OHT 9A2.1a  
Resource 9A2.1b  
as a handout

Display and explain the question on **OHT 9A2.1a**.

Find the number,  $t$ , that will give the same value for the central cell using either the upper or lower pyramid.

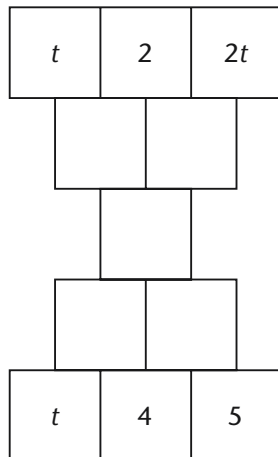

*Rule: Add adjacent expressions to give the result in the cell above (or below, for the upper pyramid).*

If pupils have had experience of pyramids before, ask them to work in pairs to arrive at the equation and to share their result with another pair. If they have not, model the process, with inputs from pupils, to arrive at the equation:

$$3t + 4 = t + 13$$

**Q What do you notice about the equation?**

Take feedback, and point out that the equation has the unknown on both sides. (Note: this question is taken from the 2003 National Curriculum test.)

**Q Does anyone know the value of  $t$ ?**

Take any answers with explanations, pointing out that these equations are generally too complicated to do in our heads.

**Q What could we do to help find the value of  $t$ ?**

Consider any responses from pupils and if necessary follow up with,

**Q Could we use the number line as before?**

Pupils could be given the opportunity to work in pairs on OHTs and then share their responses with the class. Alternatively, volunteers could work through their method at the front of the class or you could model a solution.

Point out that by matching like terms we can, in steps, arrive at simpler equivalent equations and finally at one we can solve. Say that you expect the steps to be written down (this is necessary to explain your thinking and for more difficult equations in the future). In this case:



$$\begin{aligned}
 3t + 4 &= t + 13 \\
 t + t + t + 4 &= t + 13 \\
 t + t + 4 &= 13 \\
 t + t + 4 &= 4 + 9 \\
 t + t &= 9, \quad \text{or} \quad 2t = 9 \\
 t &= 4.5
 \end{aligned}$$

**Note:** Not all pupils will need all these steps, but the steps lay the foundation for the matching method used without a number line.

The solution should be checked in the pyramid.

Ask pupils to answer similar questions using a number line if necessary – for example, those shown below (reproduced on **resource 9A2.1b**). Emphasise that intermediate steps must be shown.

- 1  $2x + 11 = 17$
- 2  $m + 9 = 2m + 4$
- 3  $5g + 6 = 11 + 3g$
- 4  $4x + 5 = x + 2.4 + 2x$
- 5  $2r + 15 = 3(r + 1)$

Adjust the difficulty of the questions for the different ability groups but all coefficients and number terms should be positive with no minus operations.

## PLENARY

15 minutes

### Resources

OHT 9A2.1a  
Resource 9A2.1b  
as a handout

### Q Was the number line useful in solving these equations?

Take feedback with explanations.

Ask pupils to choose one of their solutions, cover up the number line and see if they understand what they have done by just looking at the working. Repeat this for the pyramid question you modelled earlier (**OHT 9A2.1a**). Make the point that clear recording is very important if we want to be able to follow and share our thinking.

Ask for two volunteers to share their solutions with the rest of the class, giving pupils the opportunity to offer different steps. Get pupils to mark their neighbour's work.

For homework, ask pupils to look at the second half of **resource 9A2.1b**. Ask them to solve question 1 and then to spend 10 minutes on questions 2 and 3.

- 1  $4x + 7 = 2x + 13$
- 2  $2x + 3 = 2x + 7$
- 3  $2x - 1 = x + 9$

**Note:** In the next lesson you might discuss the solution of the equations set for homework and the difficulties that arise with questions 2 and 3 when using a number line. Pupils need to move on to 'matching' (**lesson 9A2.2**) or 'balancing' methods. The aim is that pupils become proficient in manipulating algebraic expressions and equations.

### KEY IDEAS FOR PUPILS

- The number line can help us solve equations.
- Clear recording is necessary if we want to check and share our thinking.



## Double pyramid

Find the number,  $t$ , that will give the same value for the central cell using either the upper or lower pyramid.

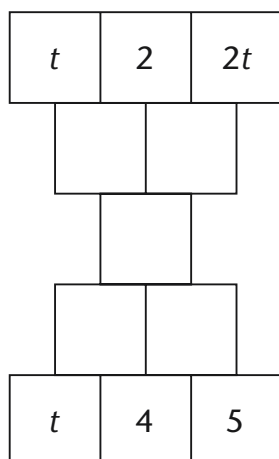

**Rule:** Add adjacent expressions to give the result in the cell above (or below, for the upper pyramid).

**9A2.1b** Equations

Use a number line to solve these.

1  $2x + 11 = 17$

2  $m + 9 = 2m + 4$

3  $5g + 6 = 11 + 3g$

4  $4x + 5 = x + 2.4 + 2x$

5  $2r + 15 = 3(r + 1)$

---

**Homework**

Use a number line to solve question 1 and then spend 10 minutes on questions 2 and 3.

1  $4x + 7 = 2x + 13$

2  $2x + 3 = 2x + 7$

3  $2x - 1 = x + 9$

# Solving linear equations using the matching method

**OBJECTIVES**

- Construct and solve linear equations with integer coefficients (unknown on both sides, without and with brackets) using appropriate methods (e.g. transforming both sides in the same way).
- Know that algebraic operations follow the same conventions and order as arithmetic operations.

**STARTER**

10 minutes

**Vocabulary**

quadrilateral  
rectangle  
expression  
term  
equivalent  
infinite

**Resources**

OHT 9A2.2a

Draw a rectangle with the dimensions shown below.

Establish that it is a rectangle and that the number represented by the unknown  $t$  has the same value in the expressions for the length and width.

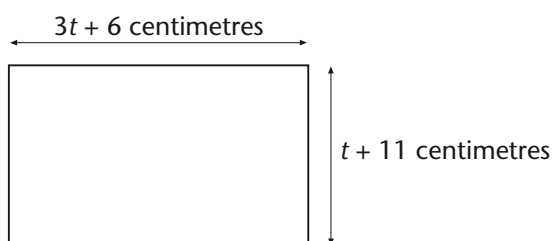

**Q How big is the rectangle?**

Take some possible dimensions for different values of  $t$ , emphasising the infinite number of possibilities.

Now focus on the side  $3t + 6$  and show the diagram on OHT 9A2.2a.

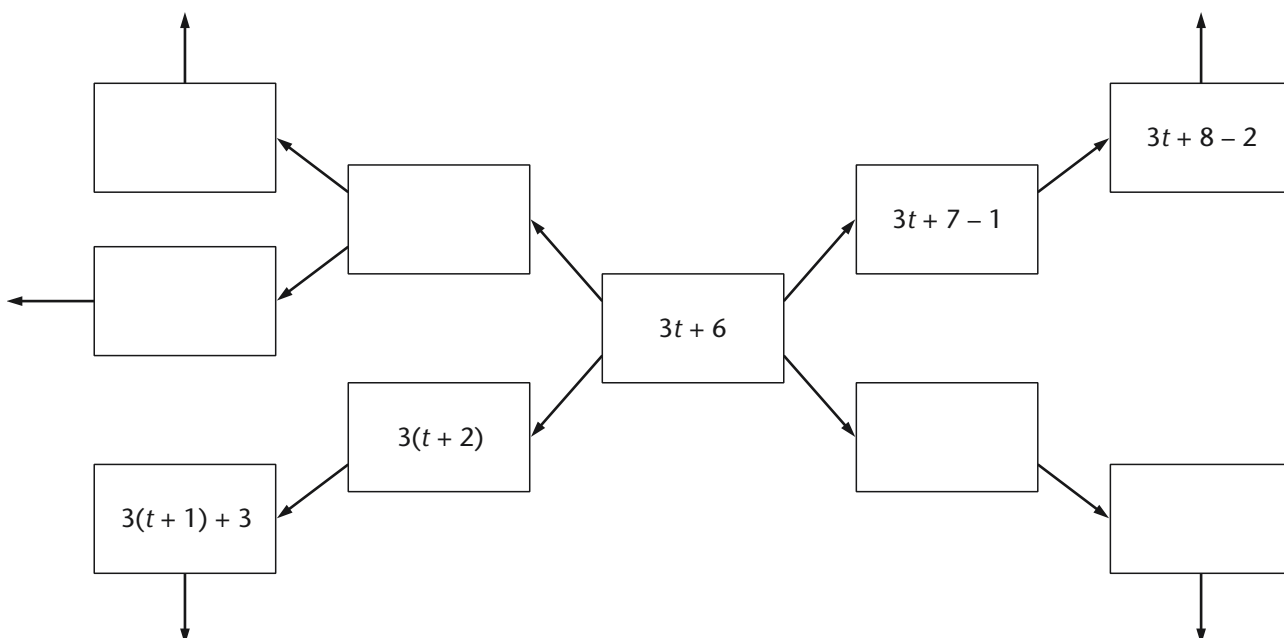

**Q In how many different ways can we write this expression?**

Explain the process used along the given branches. Ask for volunteers to start a new branch or to continue a branch. Explanations must be given and the same process or rule must be followed along a branch. Confirm that there is an infinite number of equivalent terms but the central one is the most compact.

## MAIN ACTIVITY

40 minutes

### Vocabulary

expression  
term  
like terms  
equivalent  
equation  
matching

### Resources

OHT 9A2.2b  
Resource 9A2.2c  
as a handout

Go back to the original rectangle.

**Q If this rectangle is a square what do we know?**

Come to an agreement that:

$$3t + 6 = t + 11$$

**Q What are values of  $t$  that make this equation true?**

Ask that all solutions be accompanied by an explanation, whether or not the correct solution is given. Say you are going to model a new method of solution. Refer back to the equivalent-expression diagram (OHT 9A2.2b) and say that the left-hand side (LHS) has been written in different ways. This means the equation can now be written in a number of different ways by simply writing ' $t + 11$ ', the right-hand side (RHS), equal to each of these equivalent expressions.

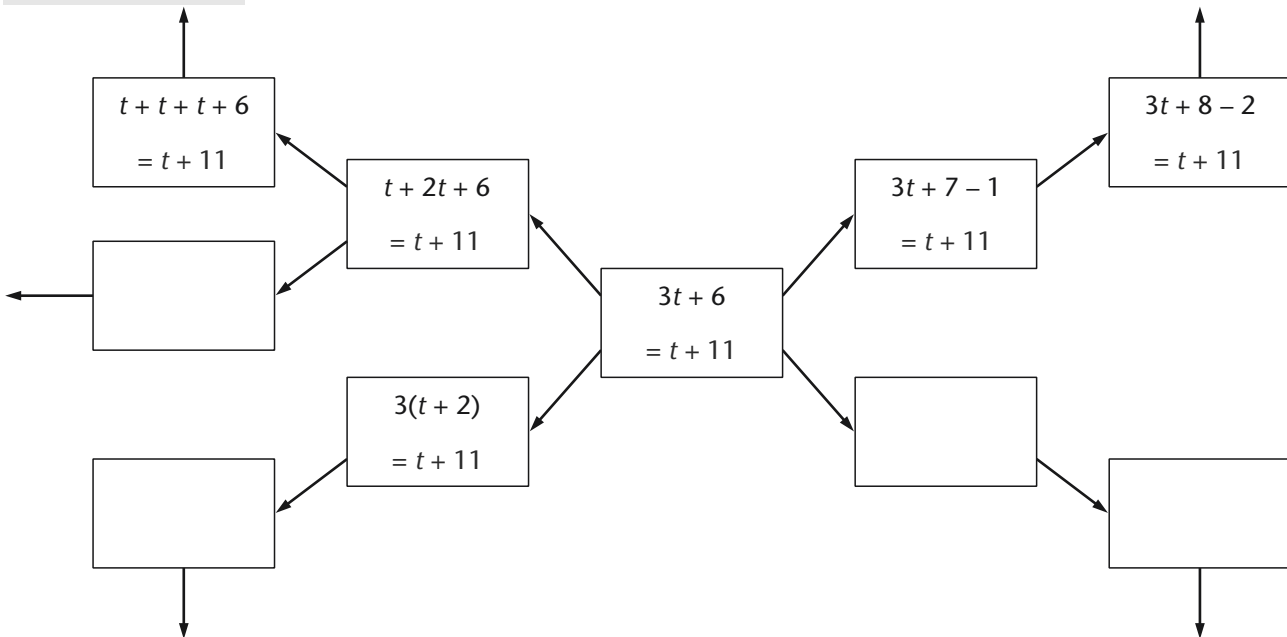

**Q Which version of the equation is the easiest to work with to find the value of  $t$ ?**

If necessary, rewrite the equations outside the diagram underneath each other.

**LHS    RHS**

$$3t + 6 = t + 11$$

$$t + t + t + 6 = t + 11$$

$$3t + 7 - 1 = t + 11$$

$$3t + 8 - 2 = t + 11$$

$$3(t + 2) = t + 11$$

Let pupils work through their suggestions in front of the class and if necessary model the following by matching equal terms:

$$\cancel{t} + t + t + 6 = \cancel{t} + 11$$

$$t + t + 6 = 11$$

$$t + t + \cancel{6} = 5 + \cancel{6}$$

$$t + t = 5$$

$$t = 2.5$$

Note that pupils will not necessarily need the same steps or number of steps.

Check the solution in the equation and in the original rectangle.

**Q Is it a square?**

Confirm this is the only solution.

Now repeat for the equation:

$$x + 13 = 2x + 7$$

Model a solution without the use of the diagram (if appropriate) by partitioning and matching like terms:

- Writing the left-hand expression in as many ways as possible.
- Writing the right-hand expression in as many ways as possible.
- Pick out expressions that have matching terms.
- Form equivalent equations that can be simplified, for example:

$$\begin{array}{lll} x + 13 = x + x + 7 & x + 6 + \cancel{7} = 2x + \cancel{7} & x + 6 + \cancel{7} = x + x + \cancel{7} \\ 13 = x + 7 & x + 6 = 2x & 6 = x \end{array}$$

If necessary the matching method (or another appropriate method) can be used to find 'easier' equivalent equations to solve.

Note that with practice pupils will partition the LHS and RHS in such a way as to target particular matches that leave a simpler equivalent equation to solve.

Ask pupils to use the matching method to solve the following equations (reproduced on **resource 9A2.2c**).

- 1  $2x + 7 = 19$
- 2  $2m + 9 = 3m + 4$
- 3  $2y - 5 = y + 7$
- 4  $4t + 5 = t + 2.4 + t$
- 5  $17 = 2(4d - 2)$

## PLENARY

10 minutes

Ask pupils to explain their solutions to their neighbour. Confirm the correct solutions and ask two pupils to share their methods with the class for questions 1 and 3, if appropriate.

**Q Is it different when solving an equation which includes a minus sign?**

Responses may confirm that the same method can be used but partitioning may be more difficult.

Note that it is important not to rush the partitioning and matching. Pupils' confidence and competence should increase with experience and ultimately provide understanding.

### KEY IDEAS FOR PUPILS

- The matching method can lead to many different equivalent equations. Try to find the easiest one to solve.
- Try to partition the two sides of the equation to make a match.
- It is important to record your thinking clearly.

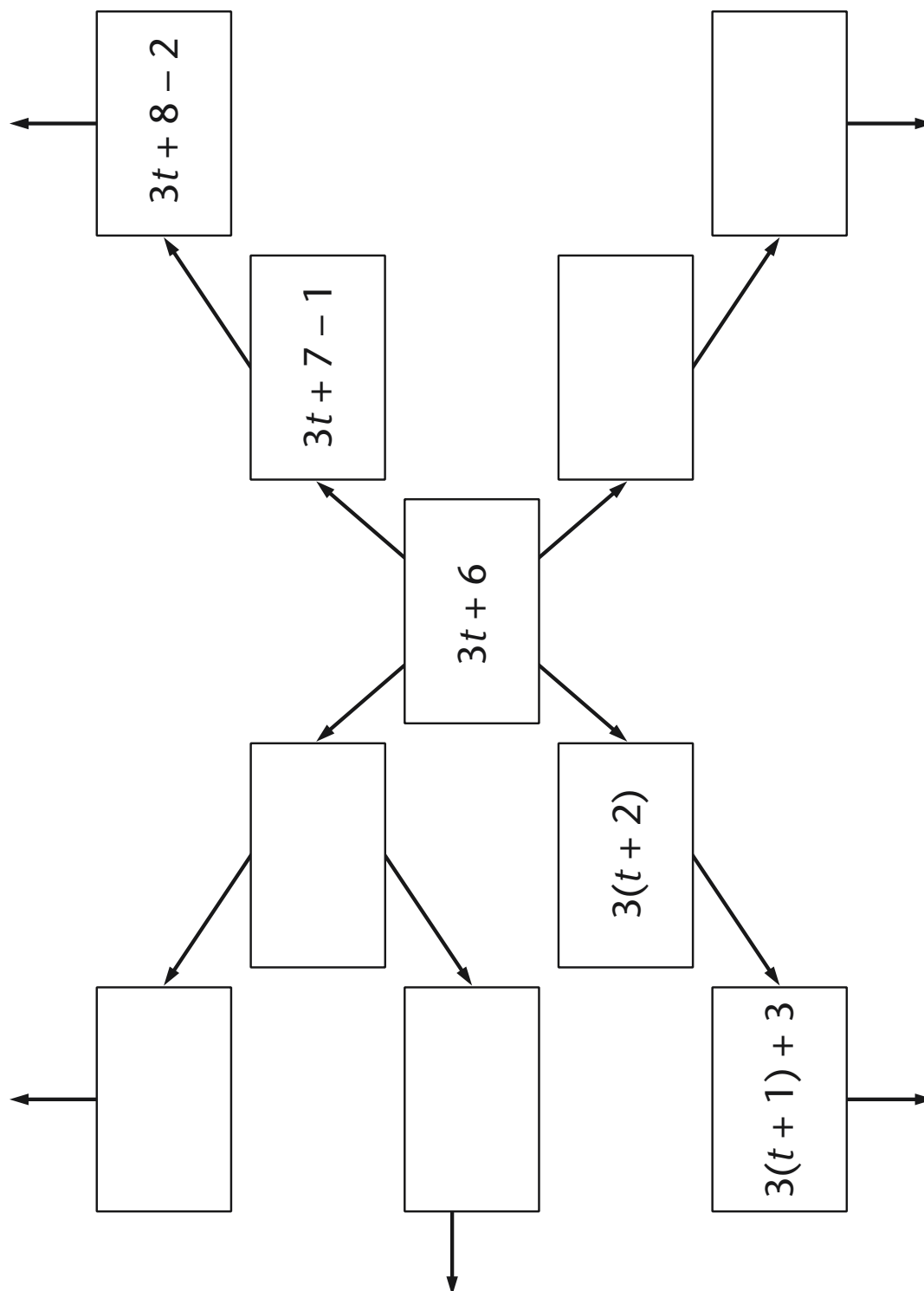

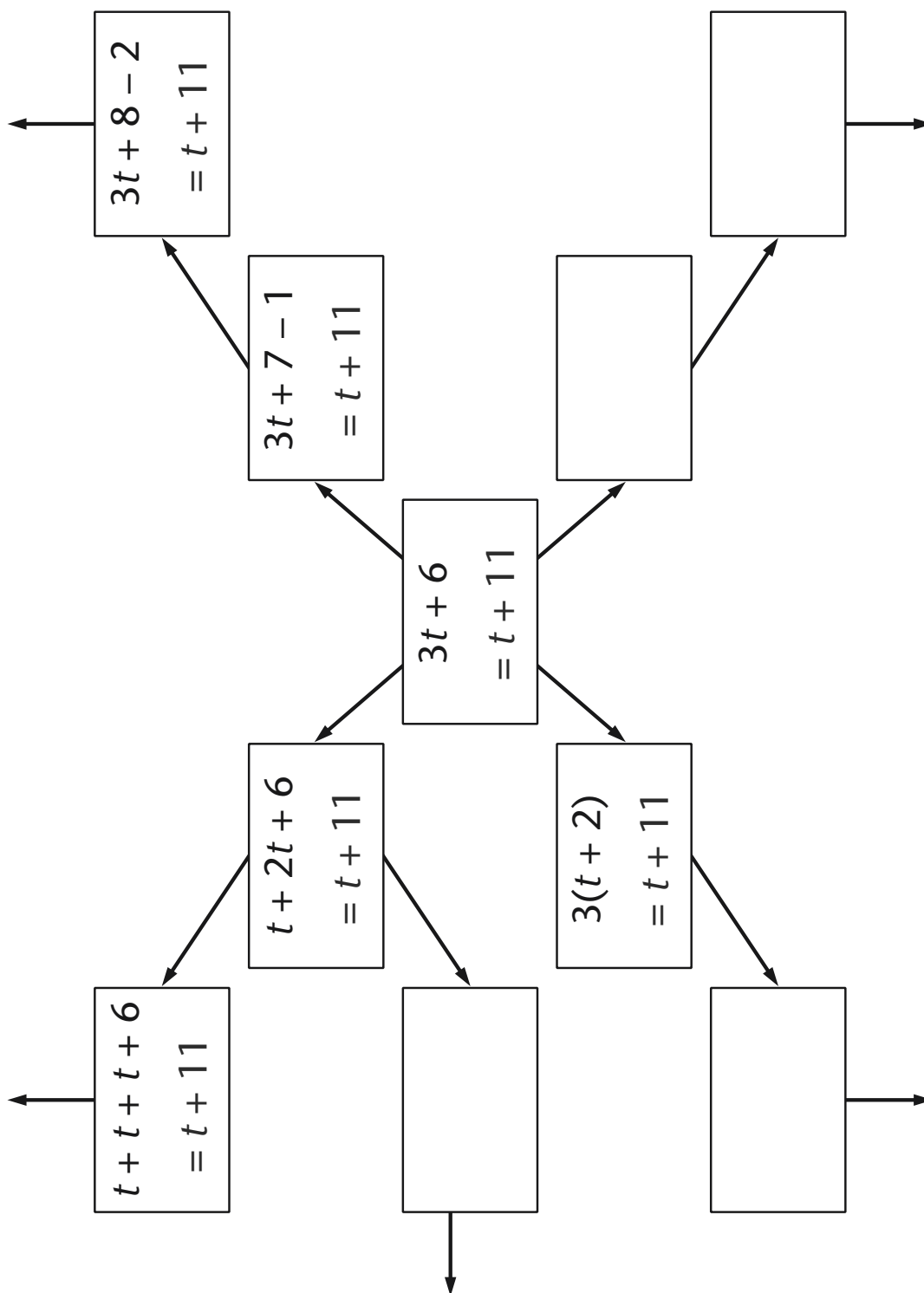

## Matching equations

Use the matching method to solve these equations.

Record your working clearly.

1  $2x + 7 = 19$

2  $2m + 9 = 3m + 4$

3  $2y - 5 = y + 7$

4  $4t + 5 = t + 2.4 + t$

5  $17 = 2(4d - 2)$



## OBJECTIVES

- Find the mode, median and range.
- Calculate the mean.
- Interpret tables, graphs and diagrams for both discrete and continuous data, and draw inferences that relate to the problem being discussed; relate summarised data to the questions being explored.
- Compare two distributions using the range and one or more of the mode, median and mean.

## STARTER

15 minutes

## Vocabulary

mean  
median  
mode  
range

## Resources

Blank OHT if required  
Mini-whiteboards

First ask pupils to explain what is meant by the terms *mode*, *median*, *range* and *mean*.

Next, list a set of numbers on an OHT or board, for example: 5, 9, 11, 7, 9.

**Q What is the mode (median, range, mean) of this set of numbers?**

You may want pupils to display answers on whiteboards.

Repeat for 15, 19, 21, 17, 19.

**Q How did you work out these answers?**

Repeat for a different set of numbers. Then say:

**Q Sam has six cards, each of which has a positive whole number printed on it. Four of the cards have the number 10. Without knowing the numbers on the other two cards can you give the value of the median, mode and range? Explain your reasoning.**

**Q The six cards have a mean of 10. What can the numbers on the other two cards be? Discuss possible answers. Which answer would give the greatest range? Why?**

Extend the discussion to include fraction and decimal values. Then say:

**Q The six cards have a mean of 10 and a range of 6. How many answers can you now find?**

**Q Can you find the values of the other two cards if the six have a mode of 6, a mean of 10 and a range of 6? Justify your answer.**

## MAIN ACTIVITY

35 minutes

## Vocabulary

compare  
greater  
less  
slightly  
significantly

## Resources

OHTs 9D1.1a and  
9D1.1b  
Framework examples,  
pages 268–271

Introduce the chart on **OHT 9D1.1a** analysing the lengths of 100 words in two newspapers. Ask pupils, in pairs, to describe what the chart shows. Allow a few minutes for them to consider and discuss their answers. Note how pupils' comments may clarify the context of the chart. Organise their statements into factual points extracted from the chart and those points that involve a comparison.

**Q What does *comparing* mean?**

Collect ideas and ensure that ideas of what is similar *and* what is different are included. Explain that when quantities differ they may be greater or less and the difference may be slight or significant.

Look back at some of the statements and develop them so that they are more explicit. For example:

- Broadsheet newspapers have significantly more longer words, i.e. of 7 and 8 letters, than tabloid newspapers.
- Broadsheet and tabloid newspapers have similar numbers of shorter words, i.e. of 1 or 2 letters.
- The modal length of word for both types of newspaper is 3.

Explain that it is important to draw inferences from the data.

**Q Why do tabloid newspapers choose to use shorter words?**

**Q Why do you think the modal length of word is 3 for both types of newspaper?**

Introduce the bar chart on **OHT 9D1.1b**. Ask pupils, initially working individually, to interpret the data in the chart. Pupils should write statements, making sure that they:

- include a comparison;
- draw on specific values from the data;
- indicate greater, more or less;
- indicate whether the difference is slight or significant;
- give a possible reason for the finding.

Pupils should then exchange statements, explain them orally to one another and then offer one another suggestions for improvement. Encourage pupils to summarise their findings. Take feedback.

Pages 261–271 of the Framework supplement provide further examples on interpreting graphs, as do Key Stage 3 test questions.

## PLENARY

10 minutes

Resources  
OHT 9D1.1c

Show **OHT 9D1.1c**, 'Teachers' ages', taken from the 2000 Key Stage 3 test.

You may choose to use the question as set or by removing some of the structure you can develop pupils' skills in using and applying mathematics.

**Q Compare the charts for male and female teachers. What do you deduce?**

You might make a link to the lesson starter.

**Q What is the modal class for female teachers?**

### KEY IDEAS FOR PUPILS

When interpreting graphs and diagrams:

- make a statement that compares two sets of data;
- use key words in a comparison statement;
- refer to values in the data;
- give possible reasons.

## Newspaper distributions

This chart shows the lengths of 100 words in two different newspaper passages. Compare the two distributions.

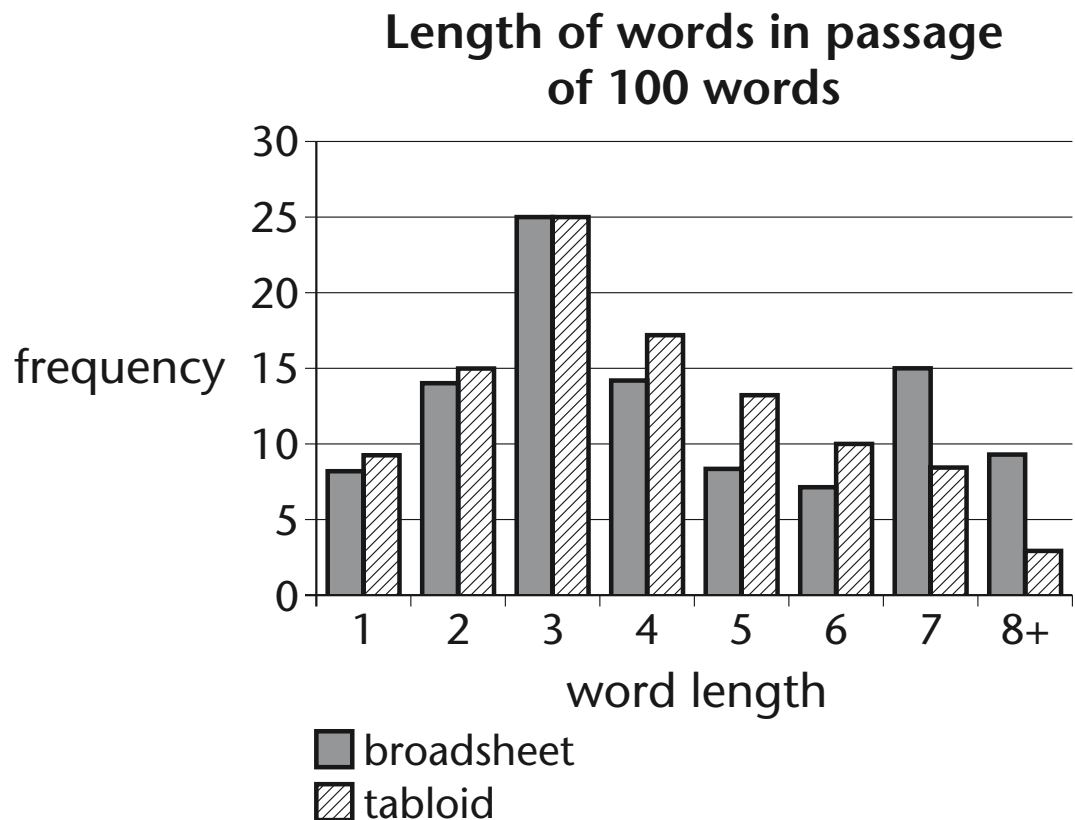

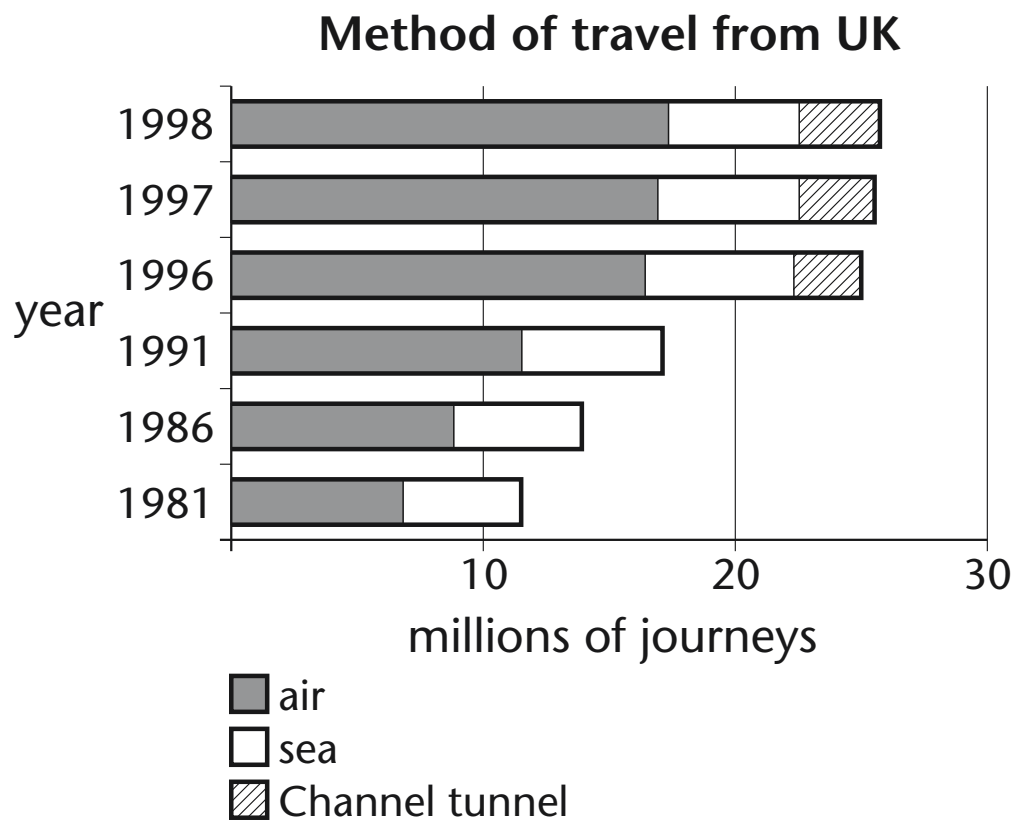

A newspaper predicts what the ages of secondary-school teachers will be in six years' time.

They print this chart.

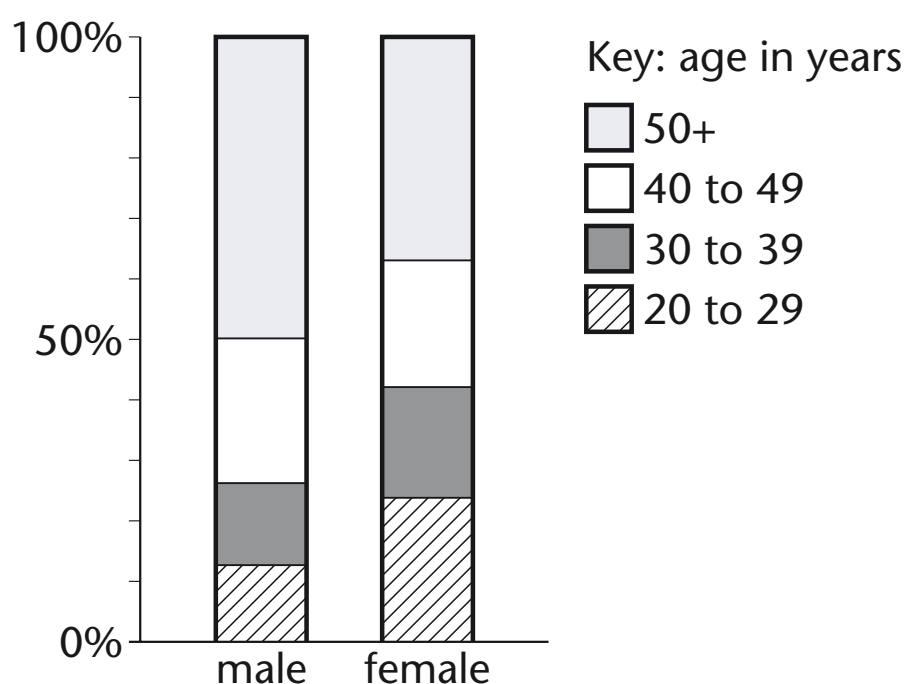

(a) The chart shows **24%** of male teachers will be aged 40 to 49.

About what percentage of female teachers will be aged 40 to 49?

(b) About what percentage of **female** teachers will be aged **50+**?

- (c) The newspaper predicts there will be about **20 000** male teachers aged 40 to 49.

Estimate the number of male teachers that will be aged 50+.

- (d) Assume the total number of male teachers will be about the same as the total number of female teachers.

Use the chart to decide which of these statements is correct.

- Generally, male teachers will tend to be younger than female teachers.
- Generally, female teachers will tend to be younger than male teachers.

Explain how you used the chart to decide.

## OBJECTIVES

- Use formulae for the area of a triangle, parallelogram and trapezium; calculate areas of compound shapes made from rectangles and triangles.
- Solve increasingly demanding problems.

## STARTER

15 minutes

## Vocabulary

See list below

## Resources

Resource 9S2.1a

Working in pairs, pupils match the areas and perimeters to the shapes on **resource 9S2.1a**.

Ask pupils to explain their answers. Check that pupils know:

- the difference between area and perimeter;
- how to calculate area and perimeter;
- formulae for the area of a triangle, rectangle, parallelogram and trapezium.

Pupils need to be secure in finding these areas and perimeters before moving on to problem solving.

## MAIN ACTIVITY

35 minutes

## Vocabulary

compound shapes  
parallelogram  
trapezium  
triangle  
units of measurement

## Resources

OHT 9S2.1b

Mixed set of word  
problems

Framework examples,  
pages 234–237

Say that pupils are going to use their knowledge of the formulae for area and perimeter to solve problems.

Model how to solve the following problem (**OHT 9S2.1b**):

*An organisation has a pentagonal logo that is made from a rectangle and an isosceles triangle. The dimensions are as follows:*

<i>Length of rectangle</i>	<i>10 cm</i>
<i>Width of rectangle</i>	<i>3 cm</i>
<i>Height of logo</i>	<i>15 cm</i>
<i>Side of isosceles triangle</i>	<i>13 cm</i>

*What is the area of the logo? How much braid is needed to go around the outside?*

Ask pupils to analyse the problem. They will need to sketch the logo.

- Q What information do you have? Label the sketch.**
- Q What information do you need to find out?**
- Q How will you calculate the area of the logo?** (Pupils will need to calculate the height of the triangle: 12 cm.)
- Q How do you work out the length of the braid that goes around the outside?**
- Q Do your calculations make sense? Check your solutions.**

After modelling the solution of another problem from the Framework, ask pupils to solve a selection of mixed word problems using area and perimeter. Use examples from the Framework examples, pages 18–19 and 234–237, and from previous Key Stage 3 test papers. For level 6 include questions on circles.

## PLENARY

10 minutes

Resources  
OHT 9S2.1c

Show **OHT 9S2.1c**, developed from a 1998 Key Stage 3 test question, and ask pairs of pupils to discuss solutions to part (a).

**Q What method can you use to solve this? Can you do it in another way? Which is most efficient?**

Discuss a variety of methods:

- One triangle has area  $\frac{1}{2}(5 \times 4)$ ; hexagon has area of 6 triangles.
- Trapezium has area  $\frac{1}{2}(5 + 10) \times 4$ ; hexagon is area of two trapezia.
- Small triangle has area  $\frac{1}{2}(2.5 \times 4)$ ; hexagon has area of 80 minus four small triangles.

The other parts of this question revise percentages and volume.

### KEY IDEAS FOR PUPILS

- Know and use formulae for the area of a triangle, parallelogram and trapezium.
- Calculate the areas of compound shapes.



# Area and perimeter match

Match areas and perimeters to the shapes.

For the area and perimeter left over, draw a rectangle that fits those dimensions.

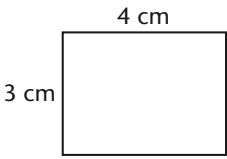
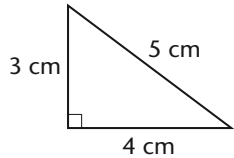
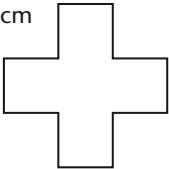
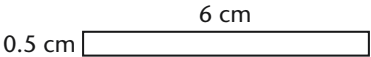
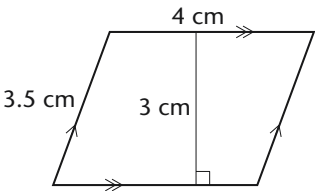
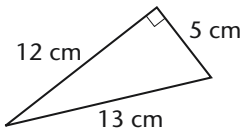
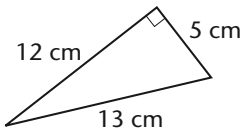
Area	Shape	Perimeter
6 cm <sup>2</sup>		12 cm
12 cm <sup>2</sup>		12 cm
24 cm <sup>2</sup>	<p>All lengths 1 cm</p> 	15 cm
12 cm <sup>2</sup>		14 cm
30 cm <sup>2</sup>		20 cm
3 cm <sup>2</sup>		13 cm
5 cm <sup>2</sup>		30 cm

## Company logo

---

An organisation has a pentagonal logo that is made from a rectangle and an isosceles triangle.

The dimensions are as follows:

Length of rectangle	10 cm
Width of rectangle	3 cm
Height of logo	15 cm
Side of isosceles triangle	13 cm

What is the area of the logo?

How much braid is needed to go around the outside?

A box for coffee is in the shape of a hexagonal prism.

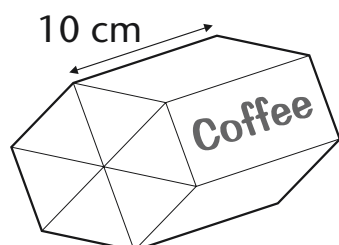

One end of the box is shown below.  
Each of the six triangles in the hexagon has the same dimensions.

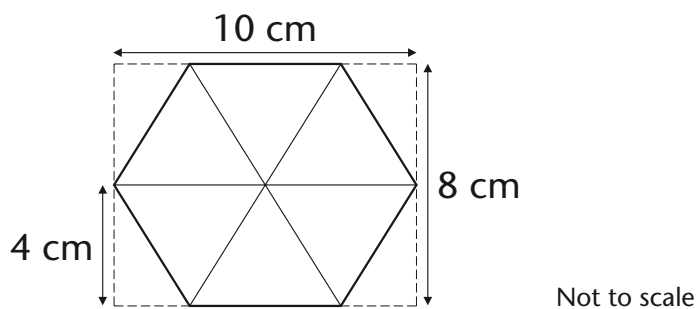

- (a) Calculate the total area of the hexagon.
- (b) The box is 10 cm long. After packing, the coffee fills 80% of the box. How many grams of coffee are in the box? (The mass of  $1 \text{ cm}^3$  of coffee is 0.5 grams.)
- (c) A 227 g packet of the same coffee costs £2.19. How much per 100 g of coffee is this?

## OBJECTIVES

- Understand and use decimal notation and place value; multiply and divide integers and decimals by 10, 100, 1000, and explain the effect.
- Read and write positive integer powers of 10.
- Extend knowledge of integer powers of 10.
- Multiply and divide integers and decimals by 0.1, 0.01.

## STARTER

10 minutes

**Vocabulary**  
See list below

**Resources**  
OHT 9N3.1a

Ask pupils to write the number 5.7, multiply it by 10 and record their answer.

Ask a pupil to read their answer aloud and to explain how they arrived at it.

**Q What has happened to the digits?** (Note that the decimal point does not move; the digits shift one place to the left.)

Repeat with numbers involving one and two places of decimals, asking pupils to multiply and divide by 100 and 1000.

**Q What do  $10^2$  and  $10^3$  mean?**

**Q How do you write 10000 as a power of 10? How do you write 10 as a power of 10? What about 1?**

Ensure that pupils recognise that increasing powers of 10 underpin decimal notation.

Extend to division to cover  $10^0$  and negative powers of 10.

Choose numbers from the place value chart (**OHT 9N3.1a**) and ask pupils to multiply and divide them by integer powers of 10 (using powers of 10).

## MAIN ACTIVITY

40 minutes

**Vocabulary**  
equivalence  
equivalent  
hundredths  
index  
place value  
power  
tenths  
thousandths  
zero place holder

**Resources**  
Handouts of 9N3.1a  
(if required for support)  
OHT 9N3.1b  
Framework examples,  
page 39

Introduce the spider diagram (**OHT 9N3.1b**). Ask pupils to explain the results and to consider other solutions, using the digits 4, 0 and 1 only. Invite pupils to show their responses and to talk through their reasoning. Make sure that  $4 = 0.04 \div 0.01$  is considered.

Discuss what happens when a number is multiplied/divided by a number less than 1.

**Q Does division always make a number smaller?  
Does multiplication always make a number larger?**

Repeat with 5.7 in the centre of the spider diagram and record pupils' responses. Establish that there are several different ways of recording the answers. For example:

$$\begin{array}{ll} 0.057 \times 100 & = 5.7 \\ 0.057 \times 10 \times 10 & = 5.7 \\ 0.057 \times 10^2 & = 5.7 \end{array} \qquad \begin{array}{ll} 0.057 \div 0.01 & = 5.7 \\ 0.057 \div 0.1 \div 0.1 & = 5.7 \\ 0.057 \div 10^{-2} & = 5.7 \end{array}$$

Ask pupils to work in groups to develop their own spider diagram showing equivalent calculations for other numbers (e.g. 3.2, 67.3, 0.43).

Remind them that their work should be recorded clearly.

Use place value charts (**handout 9N3.1a**) to support pupils as appropriate.

Differentiate by using different starting numbers for different ability groups and encourage pupils to record their responses in whichever ways they feel confident.

Move pupils on to develop their understanding of place value and notation through the following stages:

- multiplication/division by 10, 100 and 1000;
- multiplication/division by positive integer powers of 10;
- multiplication/division by 0.1 and 0.01;
- multiplication/division by negative integer powers of 10.

## PLENARY

10 minutes

Resources  
OHT 9N3.1c

Use the place value target number board (OHT 9N3.1c).

**Q** If I divide a number by 0.1 and then again by 0.1 the answer is 0.03.  
What number did I start with? How do you know?

**Q** Why do  $3.3 \times 10 \times 10$  and  $3.3 \div 0.01$  give the same answer?

Ask similar questions to check pupils' understanding.

### KEY IDEAS FOR PUPILS

- When a number is multiplied by 10/100/1000, the digits move one/two/three places to the left.
- When a number is divided by 10/100/1000, the digits move one/two/three places to the right.
- Multiplying by 0.1 has the same effect as dividing by 10.
- Multiplying by 0.01 and dividing by 100 are equivalent.
- Multiplying by  $10^{-3}$  and dividing by  $10^3$  are equivalent.

## 9N3.1a Place value chart

0.001	0.002	0.003	0.004	0.005	0.006	0.007	0.008	0.009
0.01	0.02	0.03	0.04	0.05	0.06	0.07	0.08	0.09
0.1	0.2	0.3	0.4	0.5	0.6	0.7	0.8	0.9
1	2	3	4	5	6	7	8	9
10	20	30	40	50	60	70	80	90
100	200	300	400	500	600	700	800	900
1000	2000	3000	4000	5000	6000	7000	8000	9000

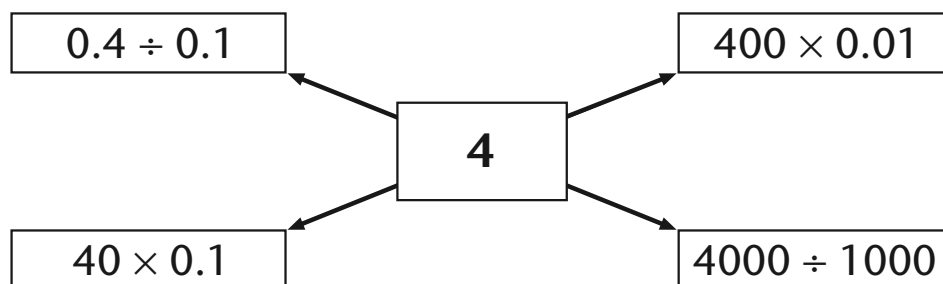

## Place value target number board

0.4	17.6	3
0.33	30	156
4000	1.56	1.76
3.3	0.0176	0.0003



## OBJECTIVES

- Make and justify estimates and approximations of calculations.
- Use a calculator efficiently and appropriately to perform complex calculations with numbers of any size; use sign change keys and function keys for powers, roots, brackets and memory.

## STARTER

10 minutes

## Vocabulary

estimate  
significant digit  
units digit

## Resources

OHT 9N3.2a  
(cut up the answers  
beforehand)  
Calculator

Introduce the grid on **OHT 9N3.2a** (note that the answers need to be cut up beforehand and spread around the grid; keep an uncut copy of the answer grid to use as a check). Ask pupils, in pairs, to match an answer with its question on the grid by estimating the answer.

Allow a few minutes, then check results:

- Q How did you estimate that?**  
**Q Did you consider the size of the numbers?**  
**Q Did you use the unit digits?**

Continue with other examples, involving other pupils, until the sheet is complete.

## MAIN ACTIVITY

40 minutes

## Vocabulary

brackets  
cube  
fraction  
keystroke  
square  
square root

## Resources

Calculators for pupils  
OHP calculator  
OHT 9N3.2b  
Framework examples,  
pages 108–109

Clarify, using examples, the use of the brackets, memory and sign change keys on a calculator. Pupils could make up an example for a partner. Invite individuals to demonstrate good examples to the class on the OHP calculator.

Explain to pupils that when doing calculations they need to decide which is the most efficient way of tackling the problem and which keys are the most appropriate.

Ask pupils to calculate problems 1–3 on **OHT 9N3.2b**:

- 1**  $(23 \times 37) - (42 \times 17)$   
**2**  $(43.6 - 17.93)^3 + \sqrt{4.68}$   
**3**  $\frac{63.2 \times 9.56}{8.2 - (3.5 - 1.49)}$

Invite pupils to demonstrate the order of their keystrokes using the OHP calculator. Highlight the use of the brackets, memory and sign change keys as appropriate.

Introduce and discuss problem 4:

- 4** Packets of biscuits are packed in boxes which hold 144 packets. A factory makes 20 000 packets of biscuits. Can all the packets be put into completed boxes? How many completed boxes will there be? How many packets will be left over?

Check that pupils are able to find the remainder and that they realise it should be an integer value.

Model ways to find this using a calculator:

$$20000 \div 144 = 138.8889.$$

Then subtract 138, the number of complete boxes.

0.8889 is a fraction of a box. How many packets is this? (128 packets)

Now set problem 5:

**5** How many days, hours, minutes and seconds are there in a million seconds?

Ask pupils to discuss the question in pairs.

**Q** How will you get started? Think about how to deal with the remainder.

## PLENARY

10 minutes

Invite a pair to explain and demonstrate their solution to problem 5 using the OHP calculator.

Make sure that pupils understand how to deal with the remainders.

As an extension, you could ask pupils how they would calculate the number of days, hours, minutes and seconds there are in 10 million seconds.

### KEY IDEAS FOR PUPILS

- Use a calculator efficiently, including the use of function keys for powers and roots, brackets, and memory.
- Know how to deal with remainders when using a calculator.

$2.3 \times 5.8$	$5130 \div 95$	$32 \times 3.8$	$371.2 \div 5.8$
$1421 \div 29$	$6.5 \times 9.8$	$2769 \div 71$	$38 \times 68$
$51 \times 61$	$1769 \div 29$	$71 \times 19$	$44.89 \div 6.7$
$2511 \div 81$	$49 \times 64$	$345.8 \div 91$	$49 \times 51$

Cut up one copy of the following into individual answers.

Keep a second copy as a check.

13.34	54	121.6	64
49	63.7	39	2584
3111	61	1349	6.7
31	3136	3.8	2499

## Calculator problems

1  $(23 \times 37) - (42 \times 17)$

2  $(43.6 - 17.93)^3 + \sqrt{4.68}$

3 
$$\frac{63.2 \times 9.56}{8.2 - (3.5 - 1.49)}$$

- 4 Packets of biscuits are packed in boxes which hold 144 packets.

A factory makes 20 000 packets of biscuits. Can all the packets be put into completed boxes?

How many completed boxes will there be?

How many packets will be left over?

- 5 How many days, hours, minutes and seconds are there in a million seconds?

What about 10 million seconds?

## OBJECTIVES

- Reduce a ratio to its simplest form.
- Divide a quantity into two or more parts in a given ratio.
- Use the unitary method to solve simple word problems involving ratio.

## STARTER

15 minutes

## Vocabulary

equivalent  
ratio notation

## Resources

OHTs 9N4.1a and  
9N4.1b

Show **OHT 9N4.1a** and ask pupils to give ratios equivalent to the one in the centre of the diagram. Then ask:

**Q Which is the simplest form of the ratio? How do you know?**

Discuss simplifying ratios, including those expressed in different units such as 5p to £1, 400 g to 2 kg, 50 cm to 1.5 m.

Show **OHT 9N4.1b** and discuss the unitary method for finding the amounts.

Ask pupils to complete the other questions mentally. Discuss their solutions.

The amount in the centre can be varied to produce questions that require mental, written or calculator methods for solution.

## MAIN ACTIVITY

35 minutes

## Vocabulary

unitary method

## Resources

OHT 9N4.1c  
Framework examples,  
page 79–81

Introduce the first problem on **OHT 9N4.1c**:

- 1** The angles in a triangle are in the ratio 9:5:4.  
Find the size of each angle.

Give pupils time to discuss this in pairs and attempt a solution. Then, through structured questions, lead pupils to the solution:

**Q What fact do you need to know about triangles?**

**Q What does 9:5:4 mean?**

**Q How would you set out your working so that someone else can understand it?**

In the same way, discuss the second question on **OHT 9N4.1c**:

- 2** Green paint is made by mixing 2 parts of blue paint with 5 parts of yellow.

A girl has 5 litres of blue paint and 10 litres of yellow paint. What is the maximum amount of green paint she can make?

Now show pupils the third example on **OHT 9N4.1c** (Framework supplement of examples, page 79).

- 3** This recipe for fruit squash is for 6 people.

300 g chopped oranges

1500 ml lemonade

750 ml orange juice

How much lemonade do you need to make fruit squash for:

- (a) 9 people?                      (b) 10 people?

Ask pupils in pairs to discuss solutions to the questions, then invite individuals to explain and demonstrate how they arrived at their answers.

**OHT 9N4.1d** lists further practice examples. Alternatively, you could use questions from previous Key Stage 3 papers.

## PLENARY

15 minutes

Resources  
OHT 9N4.1d

Discuss the solution of examples from **OHT 9N4.1d**. For example:

In a game of rugby Rob's ratio of successful kicks to unsuccessful kicks was 5:3.  
Dave's ratio was 3:2. Who was the more successful?

Note that although Rob has the better ratio you cannot tell who had the greater number of successful kicks.

Consider examples such as:

Can you split a class of 25 pupils in the ratio of 3:4?

Introduce questions of the type:

The ratio of Pat's savings to spending is 2:3. If she spent £765, how much did she save?

You could follow up with similar questions in future lessons.

### KEY IDEAS FOR PUPILS

- Divide a quantity in a given ratio.
- Solve simple problems using a unitary method.

## Ratio spider diagram 1

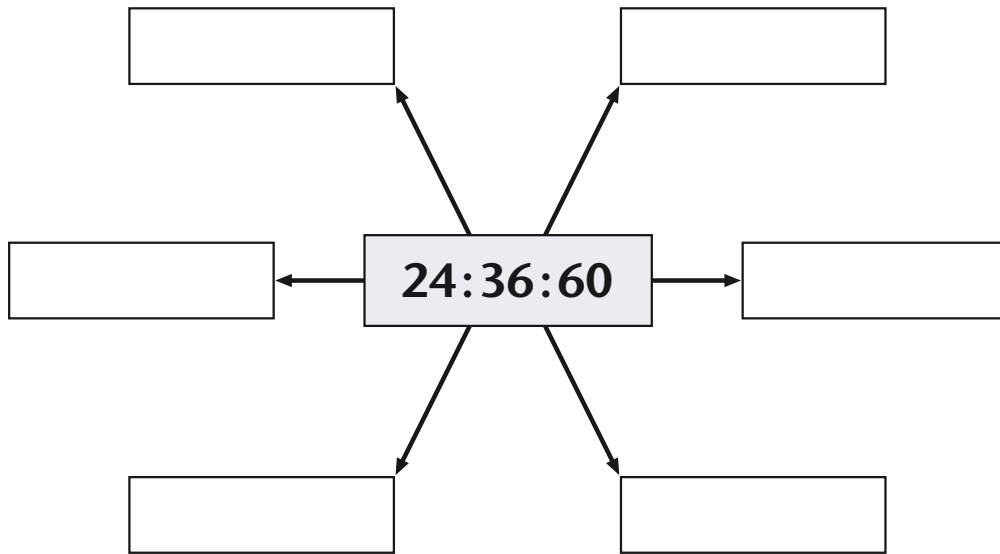

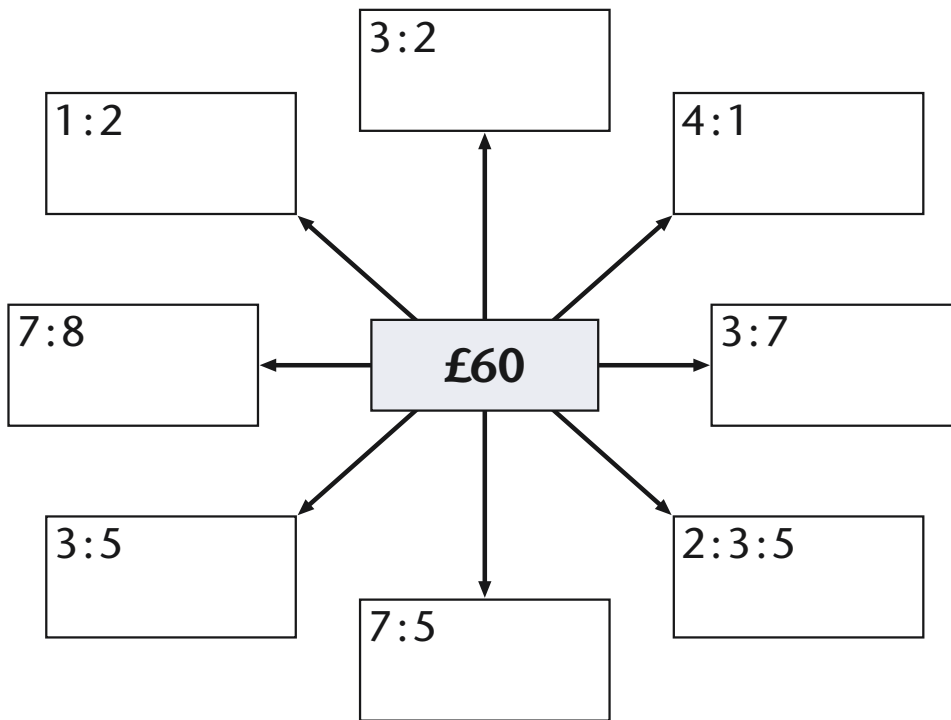



- 1 The angles in a triangle are in the ratio 9:5:4. Find the size of each angle.
  
- 2 Green paint is made by mixing 2 parts of blue paint with 5 parts of yellow.  
A girl has 5 litres of blue paint and 10 litres of yellow paint. What is the maximum amount of green paint she can make?
  
- 3 This recipe for fruit squash is for 6 people.  
300 g            chopped oranges  
1500 ml        lemonade  
750 ml         orange juice

How much lemonade do you need to make fruit squash for:

- (a) 9 people?
- (b) 10 people?

## Ratio problems 2

- 1 In a game of rugby Rob's ratio of successful to unsuccessful kicks was 5:3. Dave's ratio was 3:2.

Who was the more successful?
- 2 The gears of a bicycle travelling along a flat road are such that for every 2 turns of the pedals the rear wheel makes 5 turns.

If the pedals make 150 turns, how many turns will the rear wheel make?

When travelling up a steep hill in a different gear, would you expect the rear wheel to make more or less than 5 turns for each 2 turns of the pedals?

Explain your answer.
- 3 The answers to a survey are shown in a pie chart. The angle representing 'Yes' is  $120^\circ$ , the angle for 'No' is  $150^\circ$ , and the angle for 'Don't know' is  $90^\circ$ .

If 300 people took part in the survey, how many replied 'No'?

## OBJECTIVES

- Use ratio notation.
- Consolidate understanding of proportion.
- Begin to use graphs to solve simple problems involving direct proportion.

## STARTER

15 minutes

## Vocabulary

multiply  
proportion  
ratio  
scale

## Resources

OHTs 9N4.2a and  
9N4.2b

Show **OHT 9N4.2a** and write 6:12 in the centre. Ask pupils to give ratios equivalent to the central ratio. Through a series of questions lead pupils to the idea of a multiplier. For example:

**Q How do you get from 6 to 12?**

**Q How do you get from 6 to 12 using multiplication? Is it the same for all of the pairs of numbers in the diagram?**

Repeat with the ratio 10 : 15 in the centre.

**Q How do you get from 10 to 15 using only multiplication and division?**

**Q How do you get from 10 to 15 using multiplication?**

**Q Is it the same for all of the ratios in the diagram?**

**Q What is meant by sets of numbers being in proportion? Give me some examples.**

Show **OHT 9N4.2b**. Pupils should decide which sets of numbers are in proportion and explain their reasoning. Pupils need to grasp the idea of a constant ratio and a constant multiplier from one to the other.

Establish pupils' understanding of a set of numbers being in proportion.

## MAIN ACTIVITY

35 minutes

## Vocabulary

conversion graph

## Resources

Graph paper  
OHTs 9N4.2c and  
9N4.3d  
Framework examples,  
pages 78–81,  
172–173

Tell pupils that 50 miles is equivalent to 80 kilometres. Ask them for the equivalence of 100 miles, 20 miles, 100 kilometres, etc.

Show **OHT 9N4.2c** and ask pupils to look at the values and decide whether the pairs of numbers are in proportion. Ask them to plot the values on a graph, join up the points and describe the graph.

Show **OHT 9N4.2d** and ask pupils to look at the values in their table and decide whether the pairs of numbers are in proportion. Ask them to plot these values on a graph, join up the points and describe the graph.

Ask pupils to compare the two graphs that they have drawn: both are straight lines; 9N4.2c passes through (0, 0) and so is proportional; 9N4.2d does not pass through (0, 0) and so is not proportional.

**Extension**

**Q What is the original length of the spring?**

**Q If you plot a graph of extension against weight, what do you notice?**

Similar examples can be developed from the graphs on pages 172 and 173 of the Framework supplement.

## PLENARY

10 minutes

Resources  
Calculator

Discuss these two adverts to exchange currency:

Travel agent    Commission free, 1.50 euros for each £1  
Bank             £2 charge then 1.60 euros for each £1

**Q Which is the best deal if I have £100?**

**Q Which deal represents direct proportion?**

### *Extension*

**Q Clara changed some money at the travel agent and received 90 euros. How much would she have received if she had gone to the bank? Show your working.**

### KEY IDEAS FOR PUPILS

- Understand direct proportion.
- Recognise sets of numbers that are in proportion.
- Recognise graphs that represent direct proportion and those that don't.

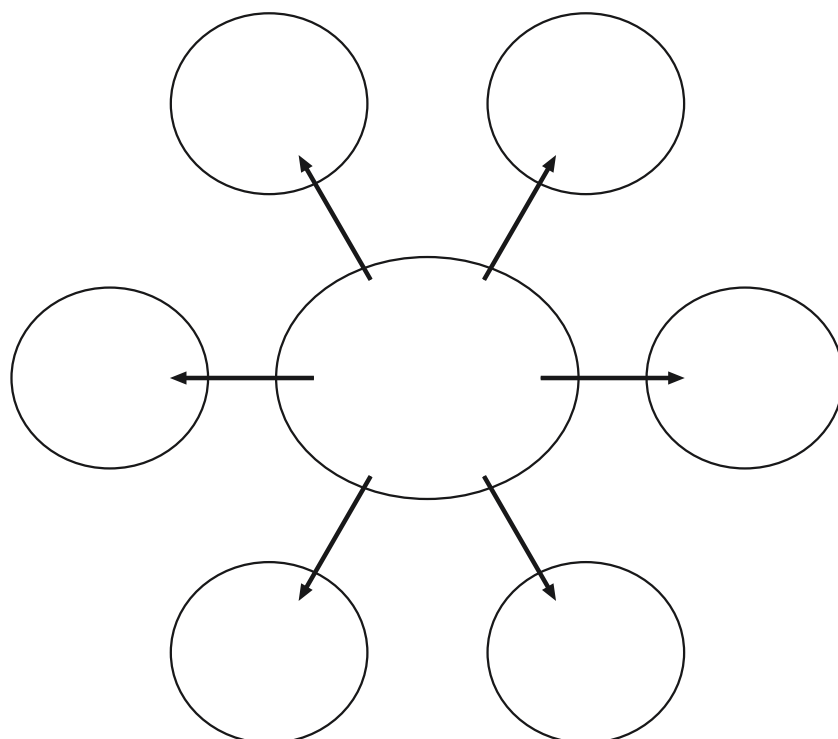

Which sets of numbers are in proportion?

**Set A**

3      6

4      8

12     24

**Set B**

3      9

4      10

12     18

**Set C**

10     5

12     6

**Set D**

12     18

4      6

Is this set in proportion?

£	\$
60	100
3	5
21	35

## Length of spring

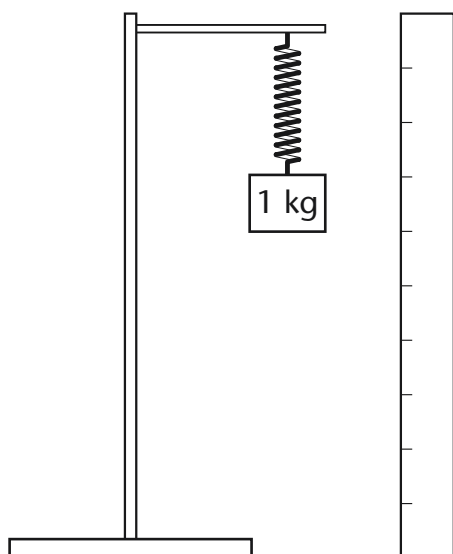

In an experiment different weights are attached to the end of a spring and the total length of the spring is measured.

When a 1 kg weight is attached, the spring is 30 cm long.

For each additional 1 kg weight, the spring extends a further 5 cm.

How long is the spring when 2 kg is attached?  
How long is the spring when 3 kg is attached?

Complete this table showing the length of the spring for different weights.

Weight (kg)	1	2	3	4
Total length (cm)				



**Note:** The materials here provide sufficient resources for two lessons.

## OBJECTIVES

- Consolidate understanding of the relationship between ratio and proportion.
- Identify the necessary information to solve a problem (by recognising problems involving direct proportion).

## STARTER

10 minutes

## Vocabulary

corresponding pairs  
direct proportion  
relationship

## Resources

OHT of data sets  
selected from  
resource 9N4.3a  
Calculators

On the OHP display a pair of data sets which are in direct proportion.  
(See resource 9N4.3a; the sets that are in direct proportion are A, B, F, I, J.)

**Q Are the two sets in direct proportion?**

**Q How do you know?**

Explore a range of different strategies to draw out different relationships between the numbers. Repeat using different pairs of sets, some in direct proportion and some not. When the pairs are in direct proportion:

**Q Can you name another pair of numbers we could include in the sets (which share the same relationship)?**

**Q How could you describe the relationship between the sets?**  
(corresponding pairs)

**Q If  $x$  is included in the first set, which  $y$  goes with it in the second? For example:**

2	7
8	28
20	70
10	?

## MAIN ACTIVITY

35 minutes

## Vocabulary

As starter

## Resources

Handout of real data  
sets selected from  
resource 9N4.3b  
Handout of problems  
selected from  
resource 9N4.3c

Describe and/or illustrate a proportion problem. For example:

**Q A bottle of diet cola indicates that 100 ml contains 0.4 kcal of energy.  
How much energy would 200 ml contain?**

Construct a table of values:

Cola (ml)	Energy content (kcal)
100	0.4
200	0.8

Include other 'easy' figures (e.g. 150 ml of cola and 1 litre of cola) and then less obvious figures (e.g. a typical glass of 180 ml).

**Q How can we work out the amount of energy?**

**Q Are the two sets of values in direct proportion?**

**Q Why? How do we know?**

Relate the answers to the table of numbers and also to the situation (i.e. the uniform nature of cola); draw out the use of 'for every'. Ensure this is well established with the class.

If time permits, use this question to confirm pupils' understanding of the situation:

**Q Can you calculate or estimate how much cola would provide 5 kcal?**

Point out that the volume of cola and the amount of energy are two values which can vary and are connected in some way. This is typical of many mathematical problems. To solve them, it is important to know how the variables are connected.

Distribute a selection of data sets from **resource 9N4.3b**. Ask pupils to work in pairs to identify quickly which sets of variables are in direct proportion. They should record their reasons briefly.

After a few minutes, select two or three of the examples and ask selected pairs to share their thinking with the class. Address any misconceptions revealed.

Now distribute a selection of problems from **resource 9N4.3c**. Ask pupils to classify them according to whether the variables are in direct proportion or not and to solve those they can.

## PLENARY

15 minutes

### Resources

OHT of situations selected from resource 9N4.3d

Address any issues which you have identified while pupils were working on the problems. Select two or three situations from **resource 9N4.3d**, and present them on an OHT.

**Q What are the variables?**

**Q Are they in direct proportion?**

**Q How can you justify your answer?**

### KEY IDEAS FOR PUPILS

- You might know that two sets of numbers are in direct proportion because you are familiar with the context and know how one variable relates to the other.
- You might observe that two sets of numbers are in proportion by looking at a table of values and noting the pattern of entries.
- Both of these points can be checked by ensuring that a constant multiplier connects every pair of values.

Proportion or not?

Which of these data sets are in direct proportion?

<b>A</b>	1	3	<b>B</b>	20	5
	2	6		28	7
	3	9		44	11
	7	21		4	1
				84	21
<b>C</b>	3	4	<b>D</b>	10	15
	7	8		12	20
	14	15		16	30
<b>E</b>	3	10	<b>F</b>	77	11
	4	13		21	3
	5	16		672	96
	6	17			
<b>G</b>	411	611	<b>H</b>	3	9
	457	657		5	25
	429	629		8	64
				10	100
<b>I</b>	42	4	<b>J</b>	14.2	65.32
	84	8		6.9	31.74
	105	10		321	1476.6
	252	24		55.55	255.53
	357	34			

# 9N4.3b

## Contextualised data sets

Consider the sets of data in context. Which sets of variables are in direct proportion?

**Playgroup – proportion or not?**

Although there is a constant difference in each column, the figures are not in direct proportion. The relationship is  $c = 8(a - 1)$ , where  $c$  stands for the maximum number of children and  $a$  for the number of adult staff.

### Playgroup

The following table shows how many adults are needed to look after different sized groups of children at a playgroup.

Number of adult staff	Maximum number of children
2	8
3	16
4	24
5	32

**Phone bill – proportion or not?**

The cost is directly proportional to the duration (30p/min) but the times may need to be converted to seconds to make the relationship clear.

### Phone bill

Calls to other networks

Duration (min:sec)	Cost (pence)
2:35	77.5
7:12	216
3:04	92
12:55	387.5
10:10	305
1:44	52

**Beethoven’s symphonies – proportion or not?**

Clearly, these figures show no proportional relationship.

### Beethoven’s symphonies

A boxed set of Beethoven’s nine symphonies provides the following information.

Symphony number	Duration of recording in minutes
1	36
2	30
3	48
4	31
5	29
6	33
7	32
8	24
9	64

**Belt prices – proportion or not?**

The two prices are very nearly in direct proportion.  
A conversion rate of £1 = €1.56 has been used, but the euro prices have been rounded to the nearest whole number.

**Belt prices**

A clothing website allows customers to pay in pounds sterling (£) or euros (€)  
These are the prices for four different belts:

£6.99 or €11  
£13.99 or €22  
£15.99 or €25  
£25 or €39

**Clicko kits – proportion or not?**

The number of base plates is not in proportion to the numbers of other components. However, the others are provided in the ratio 2:6:4:3.

**Clicko kits**

Clicko building kits come in five sizes. Their components are listed below.

Kit	Base plates	Long rods	Short rods	L-joints	H-joints
Beginner	1	10	30	20	15
Designer	1	16	48	32	24
Advanced	1	24	72	48	36
Expert	2	42	126	84	63
Supreme	2	60	180	120	90

**Cooling coffee – proportion or not?**

The temperature is not directly proportional to the elapsed time.

**Cooling coffee**

In a science experiment, the temperature of a cup of coffee is measured over half an hour. The results are tabulated.

Elapsed time in minutes	Temperature in °C
0	98
5	73
10	56
15	42
20	34
25	30
30	28

**Water drum – proportion or not?**

The depth and volume measures are in direct proportion.

**Water drum**

A large concrete drum holds water for cattle on an Australian farm. The farmer measures the depth of the water and uses this table to estimate its volume.

Depth of water	Volume
0.9 m	150 gallons
1.2 m	200 gallons
1.5 m	250 gallons
2.4 m	400 gallons

These questions require a decision about whether the variables are in direct proportion.

- 1 2.5 litres of paint are sufficient to cover 80 square metres. How much paint do I need to cover 250 square metres?
- 2 A seaside harbour has a tide marker showing the depth of water inside the harbour. At midnight the depth is 4.2 m. At 2:00 am it is 4.9 m. What will the depth be at midday?
- 3 A garage sells diesel fuel at 73.9p per litre. How much can I buy for £20?
- 4 Henry the Eighth had six wives. How many wives did Henry the Fourth have?
- 5 My recipe for 9 scones uses 200 grams of flour. How much flour will I need for 24 scones? The 9 scones need 8 minutes in a hot oven. How long will I need to cook 24?
- 6 A gardener has a lawn which is 15 m by 12 m. She decides to feed it with fertiliser applied at 1.5 grams per square metre. How much fertiliser does she need?
- 7 A sprinter can run 100 m in 11.2 seconds. How long will it take the sprinter to run 250 m?
- 8 When Robyn was 1 year old she weighed 11 kg. When she was 2 years old she weighed 14 kg. How much did she weigh when she was 4 years old?

Consider the situation rather than sets of data.  
Are the variables in direct proportion?

### True or false?

- 1 In the different countries of the world, the number of cars on the road is directly proportional to the population.
- 2 The weight of flour in a sack is directly proportional to the volume of flour.
- 3 The monthly electricity bill is directly proportional to the amount of electricity used.
- 4 The time an audio tape plays for is directly proportional to the length of tape.
- 5 The temperature of a saucepan of soup is directly proportional to the time it has been on the stove.
- 6 The cost of an article of clothing is proportional to how long it will last.
- 7 The time taken to read a maths problem and the time taken to solve it are in direct proportion.
- 8 The cost of a train journey is directly proportional to the distance travelled.

### When could we reasonably assume the following to be true and when false?

- 9 The time taken to drive a journey is directly proportional to the distance covered.
- 10 The amount of money a waitress earns is directly proportional to the number of hours she works.
- 11 The cost of a phone call is proportional to the length of the call.
- 12 The amount of wallpaper I have to buy is directly proportional to the area of the walls I want to cover.
- 13 The time taken to read a book is directly proportional to the number of pages in the book.

**OBJECTIVES**

- Use the vocabulary of probability.
- Estimate probabilities from experimental data.
- Find and record all possible mutually exclusive outcomes for single events and two successive events in a systematic way.
- Compare experimental and theoretical probabilities in different contexts.

**STARTER**

15 minutes

**Vocabulary**

equally likely  
fair  
likelihood  
mutually exclusive  
outcome  
relative frequency  
sample space

Give each group of four pupils a term from this list:

outcome  
sample space  
equally likely  
mutually exclusive  
relative frequency  
fair  
likelihood

Say that each group has three minutes to discuss and agree on their understanding of the term and how it might be used.

Take feedback from each group and clarify pupils' understanding of the terminology. Illustrate with examples.

**MAIN ACTIVITY**

35 minutes

**Vocabulary**

event  
experimental  
probability  
mutually exclusive  
sample space  
theoretical probability

**Resources**

Resource 9D2.1a, one per pair  
Scissors  
Framework examples, pages 281–285

Introduce the pairs game on **resource 9D2.1a**. Discuss how an outcome is a pair of animals and not a single animal, and that a 'success' is obtaining two identical animals ('snap').

Ask pupils to work in pairs and carry out the experiment to estimate the probability of a snap.

- Q How are you going to record your results?**
- Q How many times are you going to repeat the experiment in order to get a meaningful result?**

Allow time for pupils to complete their experiment and to calculate an estimate of the probability. Compare their estimates. Discuss any issues that arise.

Next introduce a theoretical approach to the problem.

- Q What are the possible outcomes in the pairs game?**
- Q How can you be sure that you have found them all?**
- Q How can you list them systematically?**

Encourage pupils to use a systematic method of recording the outcomes:

bb bc bd cb cc cd db dc dd

or

	b	c	d
b	bb	bc	bd
c	cb	cc	cd
d	db	dc	dd



**Q Using the list of outcomes, what is the theoretical probability of winning?**

Use additional problems from the Framework supplement of examples, Year 9, page 281.

**PLENARY**

10 minutes

Discuss the results of the pairs game experiment.

**Q How does your experimental probability compare with the theoretical one? Are they the same? If not, why are they different?**

**Q How could you improve your estimate?**

Ask other questions based on the outcomes listed.

**Q What is the probability of getting two different animals?**

**Q What is the probability of getting a bird and a cat?**

**Q Have you simplified your answer?**

**KEY IDEAS FOR PUPILS**

- Systematically record all the outcomes of an experiment.
- Increasing the number of times an experiment is repeated generally leads to better estimates of probability.
- Understand the links between experimental and theoretical probabilities.

# 9D2.1a Pairs game

A child's game has two windows.

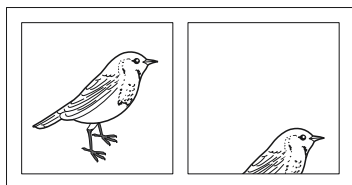

In each window, one of three different animals – a bird, cat or dog – is equally likely to appear.

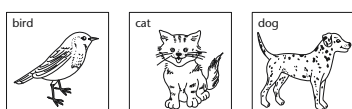

When both windows show the same animal, the child shouts 'snap' (this counts as a 'success').

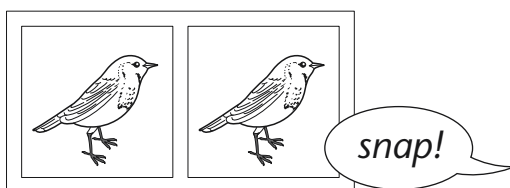

Estimate the probability of getting a 'snap', like this.

- Cut out the three animal cards, place them face down and shuffle them.
- Pick a card. This represents the animal that appears in window 1.
- Replace the card, face down. Shuffle the cards again.
- Pick a card. This represents the animal that appears in window 2.

Decide how to record this result.

Decide how many times you are going to repeat this process.

Use your results to work out the probability of getting two animals the same.

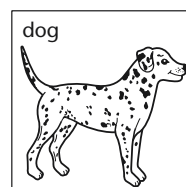
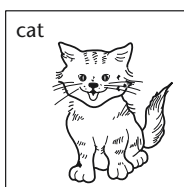
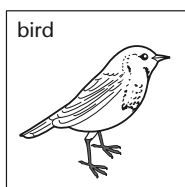

**OBJECTIVES**

- Generate and describe sequences.
- Generate terms of a sequence using term-to-term and position-to-term definitions of the sequence.

**STARTER**

10 minutes

**Vocabulary**

position  
position-to-term rule  
sequence  
term  
term-to-term rule

**Resources**

Framework examples, pages 144–145

Ask pupils to continue sequences such as:

0.7, 0.4, 0.1, ...      1005, 1003, 1001, ...

1, -2, 4, -8, ...      1, 0.5, 0.25, 0.125, ...

Make sure the level of difficulty matches examples in the Framework (pages 144–145).

**Q What is the rule to get the next term?**

Explain that you have been using a term-to-term rule to describe these sequences.

Extend the activity: give pupils the first three terms and ask for the 4th, 5th and 10th terms.

Make sure that pupils realise that there are pitfalls in continuing sequences. For example, ask them to describe these sequences:

1, 2, 4, then 8, 16, ...

1, 2, 4, then 7, 11, ...

Now give pupils the first three terms of a sequence. Ask them to suggest what the 4th and subsequent terms might be. Point out that the same few given terms can lead to several different sequences.

Spend a few minutes considering how the sequence 1, 4, 9, 16, ... can be described using term-to-term and position-to-term rules.

**MAIN ACTIVITY**

40 minutes

**Vocabulary**

expression  
general term  
generate  
justify  
nth term  
pattern  
position-to-term rule  
sequence  
symbol  
term

**Resources**

OHT 9A4.1a  
Framework examples, pages 155–157

Show the first set of shapes on **OHT 9A4.1a** and ask a pupil to draw the next shape in the pattern.

**Q How many rectangles will there be in pattern 7? How did you work it out?**

Bring out through discussion that they have used the term-to-term rule (as in the starter).

**Q How many rectangles are there in pattern 20?**

Ask pupils to discuss this in pairs and record their values.

Organise the values in a table.

Pattern	1	2	3	...	7	...	20
No. of rectangles	5	8					

Ask pupils to explain how they got the 20th term.

Counteract the misconception that you multiply the 2nd term by 10 to obtain the 20th term by offering a counter-example from the table, e.g. the 1st and 3rd terms.

Ask pairs of pupils to work out how many rectangles there are in pattern 50, and to explain their method.

Model how to write the correct general term in words and symbols, linking the explanation to the diagrams. Make sure that links are made between the numerical and spatial patterns. For example (referring to the lower diagram on **OHT 9A4.1a**):

Think of the original two rectangles (on the left-hand end). Each time three rectangles are added to form the next pattern. So:

Number of rectangles =  $2 + \text{pattern number} \times 3$  (this is a position-to-term rule)

Further examples are available in the Framework supplement of examples, pages 155–157, and on previous Key Stage 3 test papers.

## PLENARY

10 minutes

Resources

OHT 9A4.1b

Show **OHT 9A4.1b**, developed from a 1996 test question. Recap key language by asking pupils to make statements about this new sequence. For example:

The 3rd term is ...

The term-to-term rule is ...

The position-to-term rule is ...

### KEY IDEAS FOR PUPILS

- Calculate terms in a sequence.
- Express a general term in words and symbols.
- Explain how the elements of a general term relate to the original sequence.

## Tile patterns

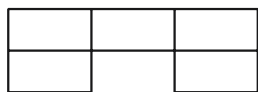

pattern 1

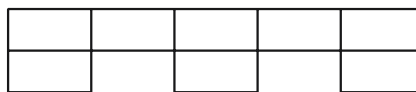

pattern 2

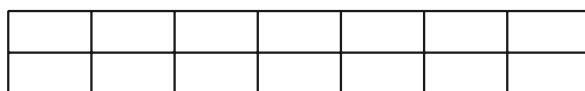

pattern 3



Start with  
2 rectangles

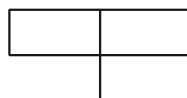

Add 3 rectangles  
each time for  
next pattern

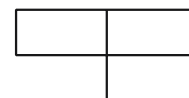

This series of patterns is made with grey and white tiles.

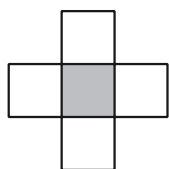

pattern 1

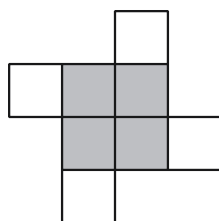

pattern 2

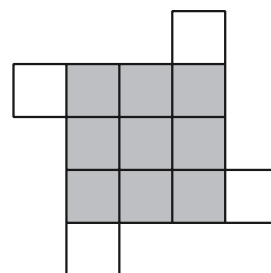

pattern 3

- (a) How many grey tiles and white tiles will there be in pattern 8?
- (b) How many grey tiles and white tiles will there be in pattern 16?
- (c) How many white tiles will there be in pattern  $n$ ?
- (d) How many grey tiles will there be in pattern  $n$ ?
- (e) How many tiles altogether will there be in pattern  $n$ ?

## OBJECTIVES

- Understand that algebraic operations follow the same conventions and order as arithmetic operations.
- Use index notation for small positive integer powers.
- Simplify or transform linear expressions by collecting like terms; multiply a single term over a bracket.

## STARTER

10 minutes

## Vocabulary

See list below

## Resources

OHT 9A4.2a

Mini-whiteboards

Show **OHT 9A4.2a**. Ask pupils to discuss in pairs which expressions match. Take feedback and ask pupils to explain their reasoning.

Next, read out the following. Ask pupils to write the expressions or equations on paper or on whiteboards, using algebra.

- 1 A number  $x$ , plus 9, then the result multiplied by 6.
- 2 Add 7 to a number  $y$ , and then multiply the result by itself.
- 3 Think of a number  $t$ , multiply it by itself and then subtract 5.
- 4 Think of a number  $z$ , square it, add 1 and then double the result. The answer is 52.
- 5 Cube a number  $p$ , and then subtract 7. The answer is 20.

Check whether pupils:

- know how multiplication is represented in algebraic expressions;
- understand the meanings of  $2n$  and  $n^2$ ,  $3n$  and  $n^3$ ;
- understand the difference between an expression and an equation.

## MAIN ACTIVITY

40 minutes

## Vocabulary

brackets  
coefficient  
equals  
equation  
evaluate  
expression  
simplify  
symbol  
term  
variable

## Resources

OHT 9A4.2b

Resource 9A4.2c, cut up and put in envelopes; one set per group  
Framework examples, page 117

Show question 1 on **OHT 9A4.2b** and ask pairs of pupils to consider the statements, identify the errors and correct them.

Invite pupils to show their responses and to talk through their reasoning.

- Q What needs to be done first?**  
**Q What is the coefficient of  $d$ ?**  
**Q Which terms can we collect together?**

Check pupils' understanding of the errors:

- the distributive law is applied incorrectly;
- there are errors in signs;
- mistakes are made in collecting terms.

At this point, it may be useful to illustrate grid multiplication with numerical examples, then extend it to:

$$\begin{array}{r|l} \times & 4 - 2p \\ \hline -2 & -8 + 4p \end{array}$$

Ask pupils to simplify the expression  $5(p - 2) - (4 - 2p)$  (question 2 on **OHT 9A4.2b**). Invite them to show their response and talk through their reasoning.

Discuss how useful it is to think of  $-(4 - 2p)$  as  $-1(4 - 2p)$ .

Next, discuss how each of the sets of expressions in question 3 on **OHT 9A4.2b** is equivalent.

Give each group of pupils the sets of expressions from **resource 9A4.2c**, to match and identify the simplified form.

**Q Which expressions do not match? Why not?**

You may need to support pupils by extending grid multiplication to include products of types  $(x + 2)(x + 3)$  and  $(x + 2)^2$ .

**PLENARY**

**10 minutes**

**Resources**

Resource 9A4.2c

Discuss particular expressions from **resource 9A4.2c**. You might focus on:

$$(a + 3)^2 - (a - 1)^2 - 3(a - 5)$$

or extend the work to expressions that involve two variables:

$$2(x + 1) + 5(y + 1)$$

If pupils are confident, an alternative plenary may be to extend the work to include factorising.

**KEY IDEAS FOR PUPILS**

- Collect like terms.
- Multiply a single term over a bracket.



## Match the expressions

Draw lines to match equivalent expressions.

Write expressions to match the two left over.

$n + n$	$n \times n$
$n \div 3$	$4n + 8$
$2n + 3$	$3 \times n$
$n^2$	$3 + n + n$
$4(n + 2)$	$2n$
$5n$	$n \div 5$
$3n$	$\frac{n}{3}$

1 What is wrong with this?

$$\begin{aligned}2(3d + 7) - 2(d - 4) &= 6d + 7 - 2d - 8 \\ &= 4d - 15 \\ &= -11d\end{aligned}$$

2 Simplify  $5(p - 2) - (4 - 2p)$ .

3 Each set of expressions below is equivalent. Can you explain why?

(a)  $3(b + 5) - (b + 3)$   
 $2b + 12$   
 $2(b + 6)$

(b)  $3(b + 5) - (b - 3)$   
 $2b + 18$   
 $2(b + 9)$

**RESOURCE****9A4.2c****Expression sort**

Cut up these cards and place them into an envelope, one set for each group of pupils.

$2(3a - 2)$	$4a^2 + 2(3a - 2) - (2a)^2$	$6a - 4$	$2 + 5a - 6 + a$
$3(a - 1)$	$(a - 5) + 2(a + 1)$	$3a - 3$	$7a - 3 - 4a$
$2a + 18$	$3(a + 5) - (a - 3)$	$2(a + 9)$	$20 + 5a - 2 - 3a$
$2(a + 6)$	$3(a + 5) - (a + 3)$	$2a + 12$	$10 - 5a + 2 + 7a$
$2(a - 6)$	$4(1 - a) + 2(3a - 8)$	$2a - 12$	$9 - 5a - 21 + 7a$
$5(a - 1)$	$(a + 3)^2 - (a - 1)^2 - 3(a - 5)$		$5a - 5$
$a - a^2$	$4a + 3 - 2a^2 - 3a + 2a^2 - 2$		$a(1 - a)$

## OBJECTIVES

- Use letters or symbols to represent unknown numbers or variables.
- Construct and solve linear equations with integer coefficients using appropriate methods.
- Solve more demanding problems; compare and evaluate solutions.
- Check a result.

## STARTER

10 minutes

**Vocabulary**  
equation  
expression

**Resources**  
Mini-whiteboards

Give pupils the statements:

John is  $y$  years old. Jane is  $x$  years old. John is 8 years older than Jane.

**Q Can you write this as an algebraic equation?**

Take suggestions and focus on  $y = x + 8$ .

Through questioning, bring out that  $y$  represents John's age in years. Emphasise that the letters represent numbers, not people.

Explain that, when you give them an instruction, you want pupils to write a new equation based on the original. Illustrate with 'add 1 to both sides' and establish that the result is  $y + 1 = x + 9$ .

Ask pupils to explain what this new equation means. Starting with this new equation, continue the process, checking and discussing at each stage: 'add 3 to both sides', 'subtract 8 from both sides'.

Next say:

John is also twice the age of Jane.

Ask pupils to write this as an equation.

You may want to repeat the process with another example.

## MAIN ACTIVITY

40 minutes

**Vocabulary**  
balancing  
negative

**Resources**  
OHT 9A4.3a  
Framework examples,  
pages 122–125

Explain to pupils that you will give them a set of equations to solve and then you will look at a problem that leads to an equation.

Point out that, whereas pupils may be able to solve some equations informally, such as  $2x + 6 = 10$ , where they can just spot the answer, for others, such as  $7x = 17$ , they may need to use a more formal method, for example transforming both sides, using inverse operations.

**OHT 9A4.3a** has three sets of questions. You need to choose the set(s) most appropriate to the needs of your pupils. Pupils targeting level 5 need to be confident with sets 1 and 2. Set 3 extends the work to level 6. You will find similar examples on page 123 of the Framework supplement of examples.

With pupils working in pairs, allow about 15 minutes for them to tackle a set of equations. Use mini-plenaries to clarify pupils' understanding, check results and discuss methods.

Emphasise the need to check solutions – most pupils will use substitution. You may want to highlight examples where different methods of solution might act as a check.

Introduce the following problem (adapted from a Key Stage 3 test question):

Multiplying my number by 4 and then subtracting 5 gives the same answer as multiplying my number by 2 and then adding 1.

Discuss setting up this problem as an equation and its subsequent solution.

More problems are to be found in the Framework supplement on pages 123 and 125.

## PLENARY

10 minutes

Resources

Mini-whiteboards

Introduce this number puzzle:

Two numbers multiply together to make 24. They add together to make 11.

Ask pupils to write answers on whiteboards and display them.

**Q How did you work it out? What did you start with?**

**Q How do you check the answer?** (Encourage pupils to check both conditions.)

Use similar examples, restricting answers to positive solutions.

For level 6 extend to include negative numbers:

Two numbers multiply together to make  $-15$ . They add together to make 2.

Two numbers multiply together to make  $-15$ . They add together to make  $-2$ .

Two numbers multiply together to make 8. They add together to make  $-6$ .

### KEY IDEAS FOR PUPILS

- Construct simple linear equations.
- Solve simple linear equations.
- Check solutions.

## Solving equations

**Set 1** 1.1  $3x = 13$

1.2  $6c + 8 = 80$

1.3  $18 = 7p - 24$

1.4  $2(n + 4) = 72$

1.5  $4(d - 1) + 3(d + 4) = 57$

**Set 2** 2.1  $9x = 43$

2.2  $7 = \frac{56}{a}$

2.3  $3x + 6 = 2x + 13$

2.4  $3(x + 2) = 4(x - 1)$

2.5  $\frac{x + 8}{2} = x - 2$

**Set 3** 3.1  $7x = -37$

3.2  $3(s - 1) - 2(s - 2) = 0$

3.3  $2(t + 1) - 5(t + 2) = 0$

3.4  $7(h + 3) = 11$

3.5  $\frac{7}{x + 2} = \frac{11}{x + 5}$

## OBJECTIVES

- Solve problems and investigate in a range of contexts.
- Explain and justify methods and conclusions.
- Identify exceptional cases or counter-examples.

## STARTER

10 minutes

Vocabulary  
explain  
reasons

Write on the board the single digits 6, 5 and 2. Say:

Rashida has three cards, each with one of these digits on it.  
None of the numbers is the same.

- Q How many different three-digit numbers can she make using each card once only?
- Q How do you know you have all of the numbers?
- Q Can any of them be square numbers?
- Q Can any of them be prime numbers?
- Q Can any of them be a multiple of 3?

Pupils must give reasons for their answers.

Take responses. Make sure reasons are full and clearly explained. Point out that for some answers particular values are sufficient but for others a full explanation is needed.

**Note:** If time is not available in this lesson, revisit the task in the next lesson with the following starter: Ask pupils if they could give the value of three different odd-numbered single-digit cards so that it is not possible to make up a prime number. Ask them to explain their answer.

## MAIN ACTIVITY

45 minutes

Vocabulary  
explain  
reasons  
(plus vocabulary  
related to  
mathematical  
context)

## Resources

OHT 9P1.1a  
Resource 9P1.1b  
Framework examples,  
pages 2–35

Show **OHT 9P1.1a**. Invite pupils' responses. You may need to structure questions to help pupils develop their explanations.

- Q What is the last digit of a number whose square ends in a 6?
- Q Could a number which ends in a 6 or a 4 be a prime number?
- Q Could the square root of this number be prime?

Explain that because the given number is even, its square root must also be even. The only even prime number is 2. However, because the given number is six digits long and greater than 100 000, its square root cannot be 2. Ask pupils to write an explanation as to why the answer must be 'No' using this information.

Tell pupils that you are going to give them a set of problems to solve. Use individual questions or a selection of problems from **resource 9P1.1b**.

Emphasise that all answers need to be supported by clear, written explanations. Point out that explanations should be easily understood and that pupils may use examples to help.

Ask pupils to work individually on a problem (or problems) and to write down their explanations and answers.

After an appropriate time, group pupils and ask them to discuss in their groups their explanations. Ask if the written answers are as clear and full as the oral explanations. Encourage pupils to decide on the best answer for each question.

Take feedback from groups to ensure they have given a complete explanation. Repeat the process with other questions.

More problems can be found on pages 30 and 31 of the Framework supplement of examples.

**PLENARY**

5 minutes

Use small plenary sessions throughout the main teaching session.

Explain the use of a counter-example when disproving a statement.

**KEY IDEAS FOR PUPILS**

- When solving problems, give full written explanations.
- Use counter-examples to disprove a statement.



## Six-digit squares

I am thinking of a six-digit square number with a units digit of 6.

— — — — — 6

Could its square root be a prime number?

Explain your answer.

- 1 Are angles A and B the same size?

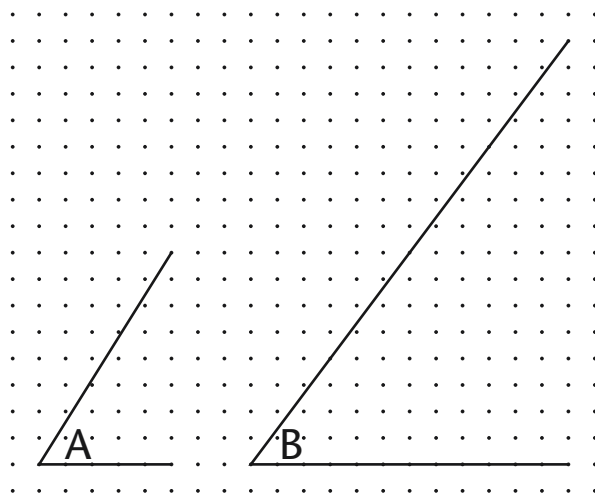

Explain your answer.

- 2 What is the largest number of obtuse angles you can have in a triangle? Explain your answer.
- 3 Find the factors of 6, 9, 12 and 25.  
Explain why only square numbers have an odd number of factors.
- 4 Screenwash is used to clean car windows.  
To use screenwash you mix it with water:  
Mix 1 part screenwash  
with 4 parts water.  
Is the statement '25% of the mixture is screenwash' correct? Explain your answer.

- 5 The number 715 is the product of three whole numbers, all greater than 1.



Find the three numbers and say if this is the only possible answer.

Explain your answer.

- 6 Graham asked 29 pupils how many times they are late getting to school in a term.

The results are shown in the table below.

Unfortunately a blot covers part of the table.

Number of days late	Frequency
0	3
1	10
2	9
3	
4	
15	1

Calculate, if possible, the mode, median, mean and range for the data.

Explain how you can calculate some values and why you are unable to calculate others.

- 7 Anne has a 5-litre jug and a 3-litre jug.

There is a large container of water.

Explain how she can end up with 4 litres of water in the 5-litre jug.

- 8 Lucy has some tiles, each with a marked corner. She sets them out as shown.

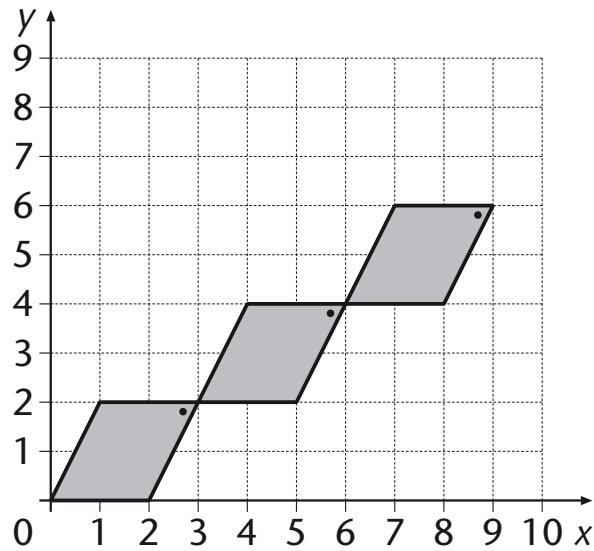

Lucy carries on laying tiles. She says: '(21, 17) will be the coordinates of one of the marked corners.'

Do you think Lucy is right?

Explain your answer.

Assim says: 'One of the marked corners is at (9, 6). If the pattern were big enough, (90, 60) would also be the coordinates of a marked corner.'

Is he right? Explain your answer.

Fred says: 'Look at the unmarked corner at (1, 2). If you continue the pattern, (100, 200) will be a corresponding corner.'

Is he right? Explain your answer.

## OBJECTIVES

- Identify the necessary information to solve a problem; represent problems and interpret solutions in algebraic, geometric or graphical form, using correct notation.
- Use logical argument to establish the truth of a statement.
- Suggest extensions to problems, conjecture and generalise.
- Consolidate understanding of the relationship between ratio and proportion; reduce a ratio to its simplest form, including a ratio expressed in different units, recognising links with fraction notation.

## STARTER

5 minutes

## Vocabulary

compare  
decimal  
equivalent  
fraction  
percentage  
proportional

## Resources

Mini-whiteboards

Point to markers on the top and bottom of a counting stick, saying that the top markers refer to multiples of 2 and the bottom markers to multiples of 5. Chant the numbers aloud as a class:

Two, five; four, ten; six, fifteen; eight, twenty; ...

Extend beyond the limit of the counting stick.

- Q If I point to 85 on the bottom, what number will be on top?**
- Q If the top number at this end of the counting stick is 18, what is the bottom number? What numbers will be at the other end of the counting stick?**

## MAIN ACTIVITY

40 minutes

## Vocabulary

direct proportion  
notation  
per, for every, in every  
proportion  
rate  
ratio

## Resources

Resources 9P1.2a and 9P1.2b, cut into cards for sorting; one set per pair of pupils – the cards are also used in lesson 9P1.3  
Enlarged cards

Explain that you are going to give out two sets of cards for pairs to sort into sets. The cards are designed to help pupils develop reasoning skills and to check their understanding of ratio and proportion.

Hold up three enlarged cards from **resources 9P1.2a** and **9P1.2b** – C, I and 1 – and pose questions for pupils to discuss in pairs:

- Q Are these cards linked in any way? Try to explain your decision to your partner.**  
Give pupils a couple of minutes, then ask two or three pairs to explain their decisions.

Pupils might say that cards C and I are linked because they are fraction and percentage equivalences for  $\frac{1}{2}$  and that card 1 is linked because the ratio of the colours is 1:2.

Say that there are different ways to interpret the images and make links, so it is important that pupils can give clear reasons for their choice of classification. They should not be inhibited by having a classification that is different to that of another pair. Encourage them to think about the rationale presented by other groups of pupils.

Ask pupils to work in pairs to identify sets of equivalent cards from **resources 9P1.2a** (cards A to P) and **9P1.2b** (cards 1 to 12), justifying their decisions.

After about 10 minutes, check on progress and ask each pair to join up with another pair to compare and explain their sets.

- Q Explain why you have put those cards together.**
- Q Does everyone understand the reasons for this grouping?**

Circulate to observe and note the different explanations being given. Probe pupils' understanding and help them to extend and refine their understanding of the links between ratio and proportion.

## PLENARY

15 minutes

### Resources

Cards enlarged from 9P1.2a on display

Display collection A, C, E, G, I, K and collection A, D, F, H, J, L. Ask pupils to discuss these collections in pairs.

**Q Can you explain to each other why these collections are correct?**

**Q Find another card to add to the collection to help explain the links.**

Ask one or two pairs to explain which card they have decided to add to the collection.



Pupils may choose to add M to A, C, E, G, I, K as this illustrates use of a ratio to compare quantities, e.g. dimensions on a rectangle.

Pupils may choose to add O, the pie chart, to A, D, F, H, J, L as this illustrates use of a ratio to compare part to whole. In this case the ratio 1 : 2 describes the two sectors relative to the whole circle. The smaller sector is  $\frac{1}{3}$  of the whole.

### KEY IDEAS FOR PUPILS

- It is important to be clear about which values are being compared.
- Values can be compared using ratio, fraction, decimal and percentage notation.

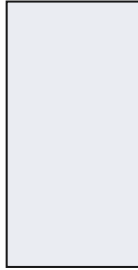
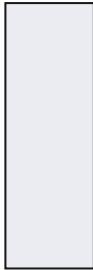
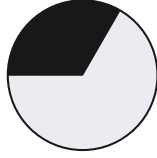
**RESOURCE****9P1.2a****Cards A–P**

<b>A</b> 1:2	<b>B</b> 1:3	<b>C</b> $1\frac{1}{2}$	<b>D</b> $1\frac{1}{3}$
<b>E</b> 2	<b>F</b> 3	<b>G</b> 0.5	<b>H</b> 0.3
<b>I</b> 50%	<b>J</b> $33\frac{1}{3}\%$	<b>K</b> 200%	<b>L</b> 300%
<b>M</b> 134 cm 	<b>N</b> $5\frac{1}{4}$ m 	<b>O</b> 	<b>P</b> 

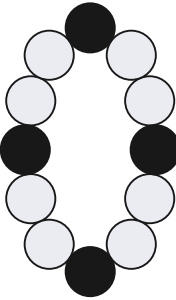
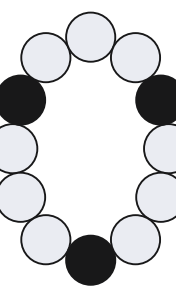
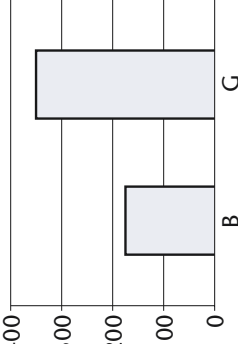
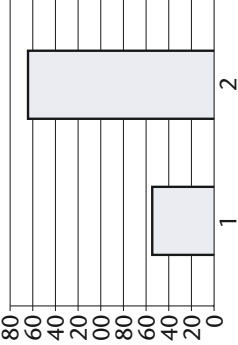
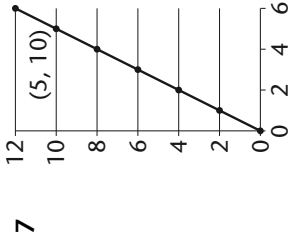
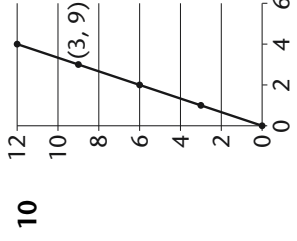
<p><b>1</b></p> 	<p><b>2</b></p> 	<p><b>3</b></p> <table border="1" data-bbox="469 725 660 1028"> <thead> <tr> <th>x</th> <th>y</th> </tr> </thead> <tbody> <tr> <td>0.25</td> <td>0.5</td> </tr> <tr> <td>3</td> <td>6</td> </tr> <tr> <td>5</td> <td>10</td> </tr> <tr> <td>12.1</td> <td>24.2</td> </tr> </tbody> </table>	x	y	0.25	0.5	3	6	5	10	12.1	24.2	<p><b>4</b></p> <table border="1" data-bbox="469 351 660 654"> <thead> <tr> <th>x</th> <th>y</th> </tr> </thead> <tbody> <tr> <td>0.25</td> <td>0.75</td> </tr> <tr> <td>3</td> <td>9</td> </tr> <tr> <td>5</td> <td>15</td> </tr> <tr> <td>12.1</td> <td>36.3</td> </tr> </tbody> </table>	x	y	0.25	0.75	3	9	5	15	12.1	36.3
x	y																						
0.25	0.5																						
3	6																						
5	10																						
12.1	24.2																						
x	y																						
0.25	0.75																						
3	9																						
5	15																						
12.1	36.3																						
<p><b>5</b></p> 	<p><b>6</b></p> 	<p><b>7</b></p> 	<p><b>8</b></p> <p>A child's portion at a restaurant costs £1.65. The adult's portion costs £4.95.</p>																				
<p><b>9</b></p> <p>A recipe for jam uses 50 g of fruit for every 100 g of jam.</p>	<p><b>10</b></p> 	<p><b>11</b></p> <p>Mobile phone bill</p> <table border="1" data-bbox="1203 725 1315 1028"> <thead> <tr> <th>Duration h:min:s</th> <th>Charge £</th> </tr> </thead> <tbody> <tr> <td>00:30:00</td> <td>0.60</td> </tr> </tbody> </table> <p>Cost per minute?</p>	Duration h:min:s	Charge £	00:30:00	0.60	<p><b>12</b></p> <p>A cat eats 4 tins of cat food in 12 days. How many tins does the cat eat each day?</p>																
Duration h:min:s	Charge £																						
00:30:00	0.60																						



**Note:** This lesson uses the same resources as lesson 9P1.2.

## OBJECTIVES

- Identify the necessary information to solve a problem; represent problems and interpret solutions in algebraic, geometric or graphical form, using correct notation.
- Use logical argument to establish the truth of a statement.
- Consolidate understanding of the relationship between ratio and proportion; reduce a ratio to its simplest form, including a ratio expressed in different units, recognising links with fraction notation.

## STARTER

10 minutes

## Vocabulary

ratio  
proportion

## Resources

Sets of cards enlarged  
from 9P1.2a and  
9P1.2b with one  
odd one out

Display enlarged cards A, C, H, M from **resource 9P1.2a**, or a similar collection on the board or OHP.

**Q Which is the odd card out? Why?**

Ask pupils to discuss in pairs and agree on an explanation. Ask two or three pairs to share their explanations.

Repeat with other sets of cards, or ask pupils to compose their own set of four with an odd card out.

## MAIN ACTIVITY

40 minutes

## Vocabulary

decimal  
direct proportion  
equivalent  
fraction  
notation  
per, for every, in every  
percentage  
proportion  
rate  
ratio

## Resources

Sets of cards from  
previous lesson; one  
set per four pupils  
Enlarged cards

Hold up enlarged cards A (1:2) and B (1:3). Tell pupils that they are going to classify the cards into two groups, each linked to one of these ratios. Ask pupils to suggest other cards which might link to each of these ratios. Emphasise that pupils should make their own decisions which they must be able to justify.

**Q Can you explain why you think this card is linked to this ratio?**

**Q Why are these cards linked?**

Ask pupils to work in groups of four and to classify the cards from **resources 9P1.2a** (cards A to P) and **9P1.2b** (cards 1 to 12) into two groups.

**Q Can you explain why you have put these images with this ratio?**

Circulate to observe and note the different explanations being used. Probe pupils' understanding of the links they have identified, helping them to extend and refine their reasoning.

Identify one or two groups to share their reasoning in the plenary.

## PLENARY

10 minutes

### Resources

Cards enlarged from  
9P1.2a

Ask pupils to choose one set of three cards, with an obvious link.

Ask pupils, in pairs, to think of a sentence they could write to describe the link between the cards.

**Q How would you explain the link between these cards?**

**Q How could you write that in a sentence?**

Take some suggestions.

### KEY IDEAS FOR PUPILS

- There are many different images that link to ratio and proportion.
- If we are comparing values we can do it in many different ways: ratio, fractions, decimals or percentages.

## OBJECTIVES

- Identify the necessary information to solve a problem.
- Solve more complex problems by breaking them into smaller steps or tasks.
- Enter numbers into a calculator and interpret the display in different contexts.
- Carry out more difficult calculations effectively and efficiently.

## STARTER

15 minutes

## Vocabulary

altogether  
difference  
sum  
total

## Resources

Resource 9P1.4a

Use **resource 9P1.4a**, which contains questions adapted from Key Stage 3 mental test papers. Read each question aloud, one at a time. Ask pupils to explain the calculation that they would do.

- Q Which key words help you decide which operation(s) to use?**
- Q Could you solve the problem another way? Which is the most efficient method?**

Highlight those questions that require two steps to reach a solution and encourage pupils to jot down the intermediate step.

## MAIN ACTIVITY

35 minutes

## Vocabulary

depends on context of  
questions

## Resources

OHTs 9P1.4b, 9P1.4c  
and 9P1.4d  
Calculators  
Framework examples,  
pages 2–25

Introduce the problem on **OHT 9P1.4b**.

Give pupils two minutes to discuss in pairs how to solve the problem, then invite one or two pairs to explain their method on the board or OHT.

Model a process of solving word problems and recording the solution clearly (**OHT 9P1.4c**).

**Stage 1: Make sense of the problem**

*Read the problem. Underline key information. Decide what you need to find out. Is any information not needed?*

If necessary, support pupils with writing frames or ask them to write down a statement: 'I need to find out ...'

**Stage 2: Calculate the answer**

*Decide what you need to calculate. Should the calculation be done mentally, using a written method or using a calculator? Show the working, if appropriate.*

Discuss when it is appropriate to use a calculator to do the calculations.

**Q What working do you need to show?**

Ensure that pupils know that when using a mental or calculator method the working is just a record of the calculations that have been done. With written calculations the working is the calculating process itself.

**Stage 3: Check the answer**

*Write down a solution to the problem. Look back at the original problem and make sure the answer makes sense.*

It might help some pupils to look back at stage 1 ('Decide what you need to find out') and write a sentence that answers this.

Now ask pupils to solve the problems on **OHT 9P1.4d**.

For further examples refer to the Framework supplement of examples, pages 2–25.

*Securing level 5 in mathematics* | Year 9 intervention

## PLENARY

10 minutes

### Resources

OHT 9P1.4d  
Mixed set of test questions

Ask a pupil to share their solution to one of the problems on **OHT 9P1.4d**. Discuss the solution, highlighting the necessary working.

Choose appropriate Key Stage 3 test questions, for example 1995 tins (non-calculator), 1996 dive rating (calculator), 2000 museum (non-calculator), and ask pupils to read the question and discuss how they would solve it.

Pupils could complete the solutions for homework or as part of a future lesson.

### KEY IDEAS FOR PUPILS

- Read the problem and identify key information.
- Carry out calculations using an appropriate method.
- Know what to record to explain your working.
- Check your answer.

## Mental questions

- 1 A room is 4.2 metres long. How many centimetres is that?
- 2 What is the sum of 2.4, 3.6, 3.6 and 4.4?
- 3 Ann bought a car for £3000. She sold it for a quarter of this price. How much did she lose on the sale?
- 4 Bruce weighs 82 kg and Wayne weighs 9 kg less. How much do they weigh together?
- 5 A CD costs £9.99. How much will 15 cost?
- 6 37% of a class are boys. What percentage are girls?
- 7 240 kilometres are equivalent to 150 miles. How many kilometres are equivalent to 50 miles?
- 8 A square has a perimeter of 36 centimetres. What is its area?
- 9 A DVD player costs £200. Its price is reduced by 15%. What is its new price?
- 10 What is the difference between £9.65 and £7.89?

The cost of hiring a van is a basic charge of £43.75 per day plus 24p per mile.

Winston hires a van for two days.

The mileage shows 23 412 at the start of the first day.

It shows 23 641 at the start of the second day.

When Winston returns the van at the end of the second day the mileage is 23 812.

How much will the van hire cost?

### Stage 1 Make sense of the problem

- Read the problem.
- Underline key information.
- Decide what you need to find out.
- Is any information not needed?

### Stage 2 Calculate the answer

- Decide what you need to calculate.
- Should the calculation be done
  - mentally?
  - using a written method?
  - using a calculator?
- Show the working, if appropriate.

### Stage 3 Check the answer

- Write down a solution to the problem.
- Look back at the original problem and make sure the answer makes sense.

- 1 A supermarket sells biscuits in three different sized packets:
  - 15 biscuits for 65p
  - 24 biscuits for 88p
  - 36 biscuits for £1.33Which packet is the best value for money?
  
- 2 Six friends went to a restaurant for lunch. The total cost for the set menu was £40.50. How much would the set menu cost for eight people?
  
- 3 Annie has some small cubes. The edge of each cube is 1.5 cm long. She makes a larger cube out of the small cubes. The volume of the larger cube is  $216 \text{ cm}^3$ . How many small cubes does Annie use?





